









Summary

VEHICLE		- Sensors.....	25
- Models' identification	1	- Cooling system	26
- Positioning of ID plates	2	MECHANICAL GROUPS	
- Dimensions	2	- Clutch.....	27
- ID Summary Plate	3	- Gearbox	27
- ID Body Paint Plate	3	- Brakes.....	29
- Weights and Loads	4	- Front suspensions	30
- Wheels and Tyres	5	- Rear suspensions.....	30.1
- Fluids and Lubricants.....	6	- Wheels' characteristic angles	30.2
- Supply Quantities.....	6/2	ELECTRICAL SYSTEM	
- Car's Lifting Points.....	6/2	- Ignition	31
- Car's Towing points	6/2	- Starting	31
ENGINES  		- Recharging	32.1
- Engine's technical features.....	7	BODY	
ENGINE  16V		- Protection products.....	33
- Engine's technical features.....	12	- Sealing products.....	33
ENGINE  TD		- Underbody protection products	34
- Engine's technical features.....	17	- Scunproofing products	35
ENGINE  T. SPARK 16V		AIR-CONDITIONING SYSTEM	
- Engine's technical features.....	22/1	- Pressure sensor calibration.....	36
ENGINES    T. SPARK 16V		- Tertiary calibration.....	36
- Engine's technical features.....	22/7	- 4-level pressure sensor calibration	36
ENGINE  JTD		- Compressor.....	36
- Engine's technical features.....	22/13	TORQUE WRENCH SETTINGS	37
ENGINE SUPPLY - COOLING		SPECIFIC TOOLS	53
- Fuel feeding	23	MAINTENANCE	
- Air feeding	24	- Maintenance operations	58
		- Maintenance of Boxer engines.....	60
		- Maintenance of 1929 Turbodiesel engines.....	71
		- Maintenance of 1970 T. Spark 16V engines.....	81
		- Maintenance of the engines:	
		1370 - 1598 - 1747 T. Spark 16V.....	86.1
		- Maintenance of 1910 JTD engines	86.3
		- Maintenance of mechanical groups	87

THE FOLLOWING GROUP CONTAINS ONLY THE SPECIFIC REFERENCES TO THE 146 MODELS;
REFER TO THE GROUP 00 REGARDING THE 145 MODELS IN CASE OF MISSING REFERENCES.

VEHICLE		- Car's lifting points	95
- Models' Identification	91	- Car's towing points	95
- Positioning of the ID plates	92	MECHANICAL GROUPS	
- Dimensions	92	- Gearbox	96
- Weights and loads	93	TORQUE WRENCH SETTINGS	99
- Wheels and tyres	94	SPECIFIC TOOLS	100
- Supply quantities.....	95		

IDENTIFICATION OF CAR VERSION

Commercial name	145 1.3/1.4	145 1.6	145 1.7 16V	145 TD	145 JTD
Equipment	3-door saloon				
Version (on identification plate)	930 A3	930 A2 930 A2A <input type="checkbox"/>	930 A1	930 A4 930 A4A ▲	930 A4B
Chassis (in the engine compartment, aside the upper connection of right shock absorber)	930000	930000	930000	930000	930000
Chassis ' number	2.001.001 4.001.001	2.001.001 4.001.001	2.001.001 4.001.001	2.001.001 4.001.001	-
Engine (code)	AR 33501	AR 33201	AR 33401	AR 67501 AR 33601 ▲	AR 32302
Engine's symbol			16V	TD	JTD
Gearbox (code)	C.802.5.16.00	C.802.5.16.02 C.802.5.16.03 <input type="checkbox"/>	C.802.5.18.00	C.510.5.17.63	C.530.5

: Only for certain markets

: Version with catalyst, only for certain markets.

Commercial name	145 	145 1.4 T. Spark	145 1.6 T. Spark	145 1.8 T. Spark
Equipment	3-door saloon			
Version (on identification plate)	930 A5	930 A3A	930 A2B 930 A2C <input type="checkbox"/>	930 A1A
Chassis (in the engine compartment, aside the upper connection of right shock absorber)	930000	930000	930000	930000
Chassis ' number	2.001.001 4.001.001	-	-	-
Engine (code)	AR 67204 AR 32301	AR 33503	AR 67601	AR 67106 AR 32201
Engine's symbol	T. SPARK 16V	T. SPARK 16V	T. SPARK 16V	T. SPARK 16V
Gearbox (code)	C.510.5.21.13 C.510.5	C.510.5.18.03 C.513.5.14.02 (1)	C.510.5.18 C.510.5.17.96 <input type="checkbox"/>	C.510.5.17.93

: Only for certain markets

(1): From chassis n°

POSITIONING OF IDENTIFICATION PLATES

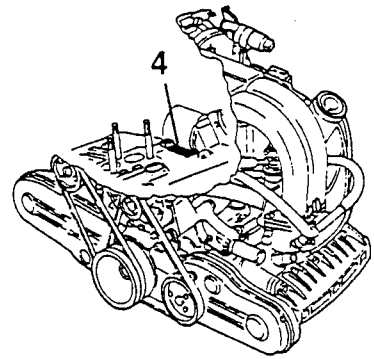
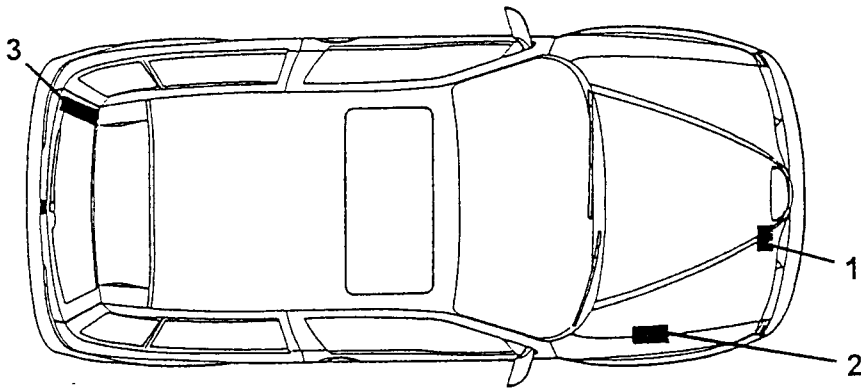

Boxer engines

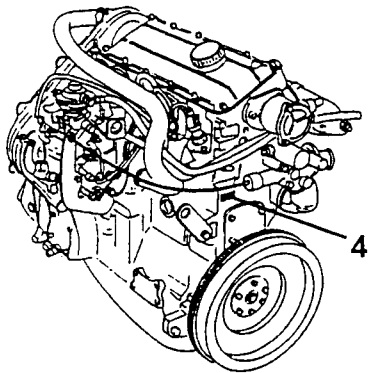

1929 TD engine

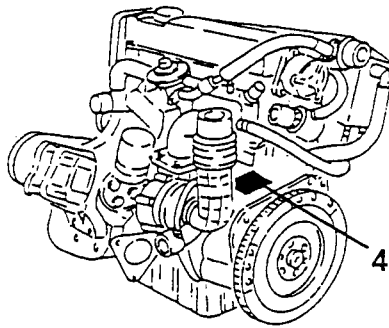

1910 JTD engine

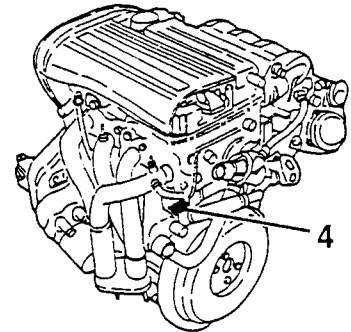



T. Spark 16V engines

- 1. Plate of summarized identification data
- 2. Body marking

- 3. ID plate of body paint
- 4. Engine marking

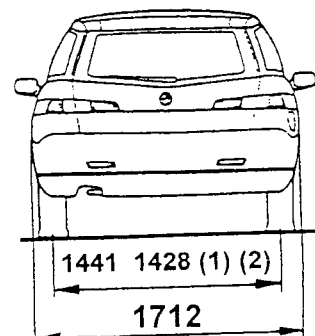
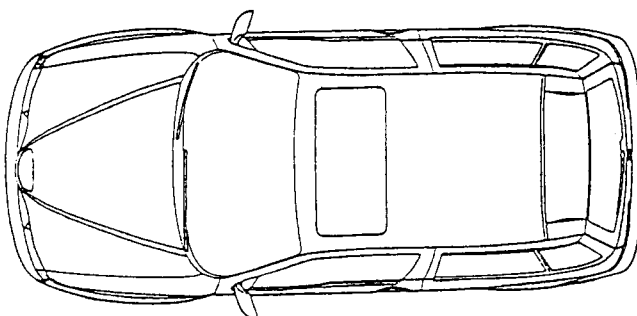
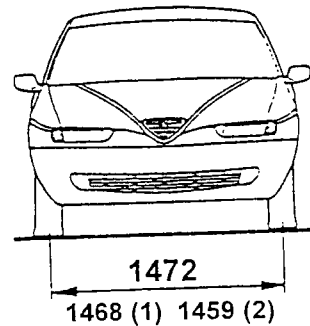
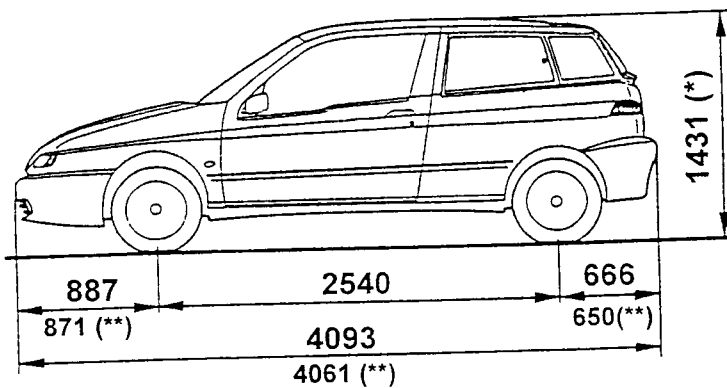
DIMENSIONS



(*): With exhausted car (**): For 99s versions (1): For 1.8 T. Spark version and  (2): For sporting version

SUMMARIZING PLATE OF IDENTIFICATION DATA

It is applied on the cross member of the engine bay. It includes the ID data as listed hereafter:

A. Manufacturer's name

 <div style="display: flex; justify-content: center; align-items: center;"> <div style="border: 1px solid black; padding: 2px; margin-right: 5px;">P</div> <div style="border: 1px solid black; padding: 2px; margin-right: 5px;">O</div> </div> <div style="border: 1px solid black; padding: 2px; margin-top: 10px; width: 20px; text-align: center;">N</div>	A		
	B		
	C	D	
	E	Kg	
	F	Kg	
	1 - G	Kg	
	2 - H	Kg	
	MOTORE - ENGINE	I	
VERSIONE - VERSION	L		
N° PER RICAMBI N° FOR SPARES	M		

B. Registration number or code

C. ID code of vehicle type

D. Number of vehicle manufacture (no. of the chassis)

E. Maximum authorized weight of the full-load vehicle

F. Maximum authorized weight at full load plus trailer

G. Maximum authorized weight on the front axle

H. Maximum authorized weight on the rear axle

I. Engine's type

L. Code of vehicle version

M. Number of spare parts

N. Correct value of grade of smoke (for Diesel engine only)

O. Supplier's code

P. Foreign producing country

Starting from the vehicle, chassis No. _____ the new ID plate is applied as follows:

 <div style="display: flex; justify-content: center; align-items: center;"> <div style="border: 1px solid black; padding: 2px; margin-right: 5px;">E</div> </div>	(F)	
	(A)	
	(B)	
	(C)	
	(C)	
	1 - (C)	
	2 - (C)	
	MOTORE - ENGINE	(D)
VERSIONE - VERSION	(D)	
N° PER RICAMBI N° FOR SPARES	(D)	

A. Lines for national registration data

B. Lines where to punch the chassis number

C. Lines to indicate the max. weight authorized by different national norms

D. Lines where to indicate the version (e.g. 930A1) and possible additional data

E. Lines where to report the grade of smoke

F. Lines where to punch the manufacturer's name

ID PLATE OF BODYWORK PAINT

Verniciatura originale Peinture originale/Original painting Originallackierung/Pintado original	A
Colori/Tinte/Colour Farben/Color	B
Codici/Code/Codigo	C
PER RITOCCHI E RIVERNICIATURE	D

It is applied in the internal part of the rear bonnet and shows the following data:

A. Paint's manufacturer

B. Colour's name

C. Colour's code

D. Colour's code for touch-ups or repainting

WEIGHTS AND LOADS

Unit: kg

Features		Versions	930 A3	930 A2 930 A2A	930 A1	930 A4 930 A4A	930 A4B
		Weight in running order (without driver)		1140	1140	1190	1245
Maximum weight allowed			1670	1670	1715	1765	1730
Payload			530	530	525	520	520
Maximum weight allowed per axle	front		950	950	950	950	950
	rear		850	850	850	850	900
Towable weight	with braked trailer		1100	1100	1200	1300 1300 (*)	1300 1300 (*)
	with unbraked trailer		350	350	350	350	350
Maximum load on the ball			50	50	50	50	50

(*) : Homologated for Switzerland only.

Features		Versions	930 A5	930 A3A	930 A2B 930 A2C	930 A1A
		Weight in running order (without driver)		1240	1135	1165
Maximum weight allowed			1765	1655	1685	1715
Payload			525	520	520	520
Maximum weight allowed per axle	front		950	950	950	950
	rear		900	900	900	900
Towable weight	with braked trailer		1200 1200 (*)	1100 800 (*)	1200 900 (*)	1200 900 (*)
	with unbraked trailer		350	350	350	350
Maximum load on the ball			50	50	50	50

(*) : Homologated for Switzerland only.

WHEELS AND TYRES

CAR	DIMENSIONS Rims Tyres		Pressures (bar)			
			REDUCED LOAD (2 people)		FULL LOAD	
			FRONT	REAR	FRONT	REAR
930 A3	Standard equipment	5.5J x 14" 175/65 R14" 82T	2.2	2	2.5	2.5
	Optional equipment	5.5J x 14" 185/60 R14" 82H				
930 A2	Standard equipment	5.5J x 14" 175/65 R14" 82T	2.2	2	2.5	2.5
	Optional equipment	5.5J x 14" 185/60 R14" 82H (*)				
930 A2A	Standard equipment	5.5J x 14" 185/65 R14" 86T	2.2	2	2.5	2.5
930 A1	Standard equipment	5.5J x 14" 185/60 R14" 82H	2.2	2	2.5	2.5
930 A4 930 A4A	Standard equipment	5.5J x 14" 175/65 R14" 82T	2.2	2.1	2.5	2.5
	Optional equipment	5.5J x 14" 185/60 R14" 82H				
930 A4B	Standard equipment	5.5J x 14" 185/60 R14" 82H	2.2	2.0	2.5	2.5
	Optional equipment	6J x 15" 195/55 R15" 84V				
930 A5	Standard equipment	6J x 15" 195/55 R15" 84V	2.3	2.1	2.5	2
930 A3A	Standard equipment	5.5J x 14" 6J x 15" (▲) 185/60 R14" 82H 195/55 R15" 84V (▲)	2.2	2	2.5	2.5
930 A2B	Standard equipment	5.5J x 14" 6J x 15" (▲) 185/60 R14" 82H 195/55 R15" 84V (▲)	2.2	2	2.5	2.5
930 A2C	Standard equipment	5.5J x 14" 185/60 R14" 82H	2.2	2	2.5	2.5
930 A1A	Standard equipment	6J x 15" 195/55 R15" 84V	2.2	2	2.5	2.5
ALL	SPARE SMALL WHEEL 4J x 15" (in steel) 4.00B x 15" (in alloy) - 115/70 R15" 90M		4.2			

(*) : Standard for certain markets

(▲) : For sport equipment (for versions/markets if envisaged)

WARNING: In case of continuous running in max. gears, pressures to be increased by 0.3 bar.

FLUIDS AND LUBRICANTS

Type	Reference Group	Application	Classification	Name	
OIL	10 - Engine	Engine (Supply)	- BOXER - T.SPARK 16V	API SJ SAE 10W/40 ACEA A3-96	SELENIA 20K (1)
			1929 TD 1910 JTD	API CD SAE 10W/40 ACEA B3-96	SELENIA TURBODIESEL SAE 10W/40
	21 - Gearbox	Gearbox-Differential (Supply)	BOXER	API GL5 SAE 80W/90	TUTELA W 90/M - DA
			- 1929 TD - 1910 JTD - T.SPARK 16V	SAE 75W/90 API GL - 5	TUTELA ZC 75 SYNTH
	50 - Subsidiary elements	Compressor (Supply)	BOXER	-	SANDEM SP 10 "PAG"
			1929 TD	-	UCON RL - 488
			1919 JTD	-	PAG SP 20
			T.SPARK 16V	-	NIPPONDENSO ND-9
	FLUID	10 - Engine	Cooling circuit (Supply)	-	ALFA ROMEO CLIMAFLUID SUPER PERMANENT -40°C
		18 - Clutch	Hydraulic Circuit Brakes - Clutch (Supply)	DOT 4 SAE J 1703 F	ALFA ROMEO BRAKE FLUID SUPER DOT 4
		33 - Brakes			
		41 - Steering	Hydraulic Driving System (Supply)	G.M. DEXRON II	TUTELA GI/A
50 - Subsidiary elements		Conditioning circuit system (Supply)	-	RIVOIRA: SUVA R134a HOECHST-TAZZETTI: FRIGEN R134a ICI-TAZZETTI: KLEA R134a	

(1): - In case of highly sporting use of the vehicle, it is advisable to use the engine oil **SELENIA Racing 10W/60**, which is wholly synthetical.

- In case of severe and very cold weather conditions, it is advisable to use the engine oil **SELENIA Performer 5W30, ACEA1, API SJ**.

FLUIDS AND LUBRICANTS (Continued)

Type	Reference Group	Application	Classification	Name	
GREASE	10 - Engine	Seat for intake manifold on water pump	1929 TD	- SIL 133 MOLDGUARD	
	18 - Clutch	Work seat for step bearing	BOXER	-	TUTELA MR 3
		Seat for step bearing and shaft of clutch control	- 1929 TD - T. SPARK 16V		
		Cylinder cap clutch control			
	21 - Gearbox	External rings taper bearings pinion and differential box	BOXER	-	TUTELA MR 3
		External surface: - spacer to fix rod and gear control lever; - spacer to fix lever and fork; - guide for gear control lever		-	TUTELA ZETA 2
		Rod bushings gearshift control and spheric of gear lever	- 1929 TD - T. SPARK 16V	-	ISECO MOLYKOTE LONGTERM N. 2
	27 - Front axle	Homokinetic couplings half shafts		-	OPTIMOL OLISTAMOLY 2LN 584 MOLYKOTE VN 2461/C TUTELA MRM 2
	33 - Brakes	Knuckles and bushings Pedals		-	TUTELA ZETA 2
		Seats of inductive sensors A.B.S.			
	41 - Steering	Seat of rolled bush on the support of the steering column		-	SPCA SPAGRAPH ISECO ERGON RUBBER GREASE REINACH SFERUL B2 AR
	44 - Suspensions and wheels	Flexible supports and swinging arms		-	GREASE MOLYKOTE 7544 PG54 TUTELA MR3
Side track rods of the steering			-	MOLYGUARD SYL 113	

RELEVANT SUPPLY QUANTITIES

Versions		930 A3	930 A2 930 A2A	930 A1	930 A4 930 A4A	930 A4B	930 A5	930 A3A 930 A2B 930 A2C 930 A1A
		Supply capacities						
Fuel tank		51 liters			51/61 liters (*)			
Fuel stock		5 ÷ 8 liters						
Engine oil	Total capacity: pan + filter + sumps + radiator	4.7 liters	5.2 liters	6 liters	(**)	5.0 liters		
	Pan + filter (for recurrent replacement)	4 liters	4.5 liters	5 liters	4.2 liters	4.4 liters		
Oil for gearbox - differential		2.4 liters		2 liters		2 liters		
Oil for hydraulic driving system		1.1 liters			900 gr		1.3 liters	
Oil for brakes and clutch		0.4 kg		0.5 kg	0.4 kg (▲)	0.5 kg		
Fluid for engine cooling system		7.8 liters		8.9 liters	6.1 liters	8.3 liters	8.4 liters	
Oil for conditioning compressor		240 ± 15 cm ³		236 ± 15 cm ³	130 g	150 ± 20 cm ³		
Fluid for conditioning system		0.700 kg			(**)		0.700 kg	

(*): For Versions/Markets
(▲): With A.B.S. = 0.54 kg

(**): Data which are not available while printing.

CAR LIFTING POINTS

With bridge or workshop autolift.

- The car is to be lifted by placing the arms' ends or the autolift as shown.

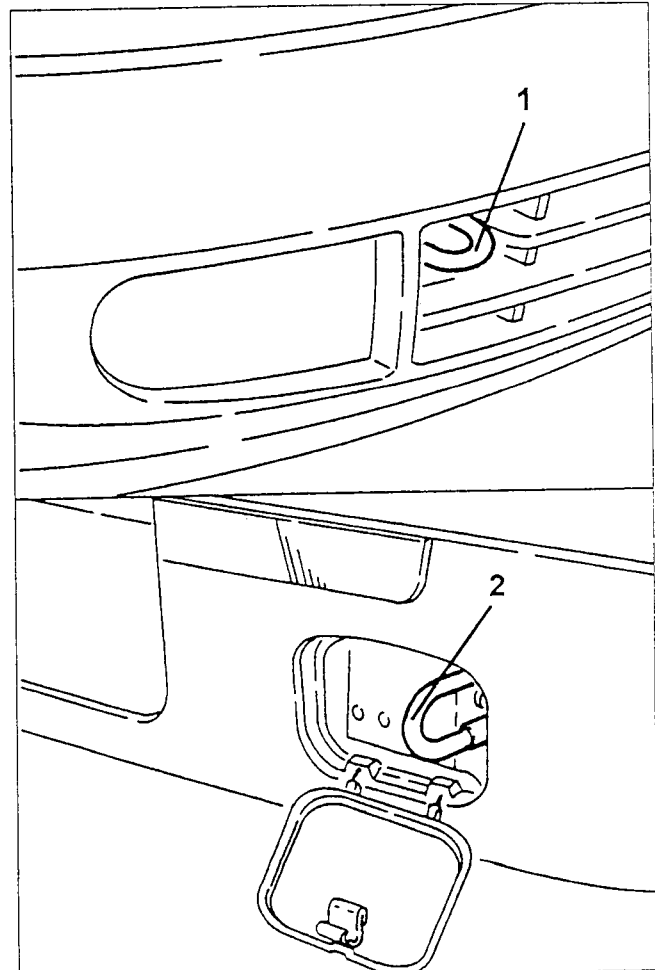
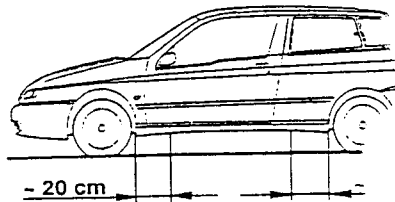

1. Front hitch

2. Rear hitch

CAR TOWING POINTS

The car is equipped with two rings, a front and a rear one, located on the right side of the bumper. The rear ring is covered by a door that can be opened by pressing on its edge. Please comply with the existing norms in matter of tow operations.

Before the towing operation, the key must be turned onto MAR position and hence is to be turned back onto STOP position without removing it; in this way the steering block will be avoided.

It is important to know that, in case of towing, there is no depression in the servo brake, it is therefore necessary to press the brake pedal with increased strength.

WEIGHTS AND LOADS

Unit: kg

Characteristics		Versions	930 B2B	930 B1A	930 B5
Kerb weight (without driver)			1190	1215	1275
Maximum allowed weight			1710	1735	1800
Useful load			520	520	525
Max. permissible weight per axle	front		950	950	950
	rear		900	900	900
Towable weight	with braked trailer		1200	1200	1200
	with trailer without brakes		350	350	350
Maximum load on tow hook			50	50	50

WHEELS AND TYRES

MODEL	Rim - Tyre SIZES	PRESSURE (bar)			
		MEDIUM LOAD (2 persons)		FULL LOAD	
		FRONT	REAR	FRONT	REAR
930 B2B	5.5J x 14" 185/60 R14" 82H	2.2	2	2.5	2.5
	6J x 15" (*) 195/55 R15" 84V (*)	2.2	2	2.5	2.5
930 B1A	6J x 15" 195/55 R15" 84V	2.2	2	2.5	2.5
930 B5	6J x 15" 195/55 R15" 84V	2.3	2.1	2.5	2.5

(*): For Junior version (only for some versions/markets).

MODEL IDENTIFICATION

Trade name	145 1.3/1.4	145 1.6	145 1.7 16V	145 TD	145 JTD
Trim level	3-door saloon				
Version (on identification label)	930 A3	930 A2 930 A2A □	930 A1	930 A4 930 A4A ▲	930 A4B
Chassis (in the engine compartment to one side of the right-hand upper shock absorber attachment)	930000	930000	930000	930000	930000
Progressive chassis number	2.001.001 4.001.001	2.001.001 4.001.001	2.001.001 4.001.001	2.001.001 4.001.001	-
Engine (code)	AR 33501	AR 33201	AR 33401	AR 67501 AR 33601 ▲	AR 32302
Engine symbol			16V	TD	JTD
Gearbox (code)	C.802.5.16.00	C.802.5.16.02 C.802.5.16.03 □	C.802.5.18.00	C.510.5.17.63	C.530.5.XX.YY (*)

(□): Only for some Markets

(▲): Version with catalyst only for certain Markets

(*): For future publication.

Trade name	145 	145 1.4 T. Spark	145 1.6 T. Spark	145 1.8 T. Spark
Trim level	3-door saloon			
Version (on identification label)	930 A5	930 A3A	930 A2B 930 A2C □	930 A1A
Chassis (in the engine compartment to one side of the right-hand upper shock absorber attachment)	930000	930000	930000	930000
Progressive chassis number	2.001.001 4.001.001	-	-	-
Engine (code)	AR 67204 AR 32301	AR 33503	AR 67601	AR 67106 AR 32201
Engine symbol	T. SPARK 16V	T. SPARK 16V	T. SPARK 16V	T. SPARK 16V
Gearbox (code)	C.510.5.21.13 C.510.5.XX.YY (*)	C.510.5.18.03 C.513.5.14.02 (1)	C.510.5.18 C.510.5.17.96 □	C.510.5.17.93

(□): Only for some Markets

(1): From chassis no.

(*): For future publication.

LOCATION OF IDENTIFICATION LABELS

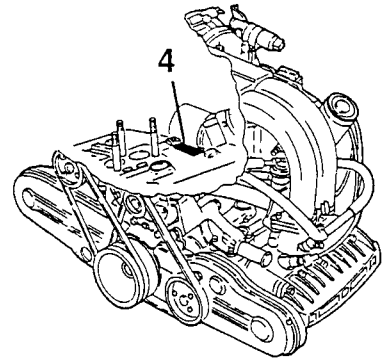
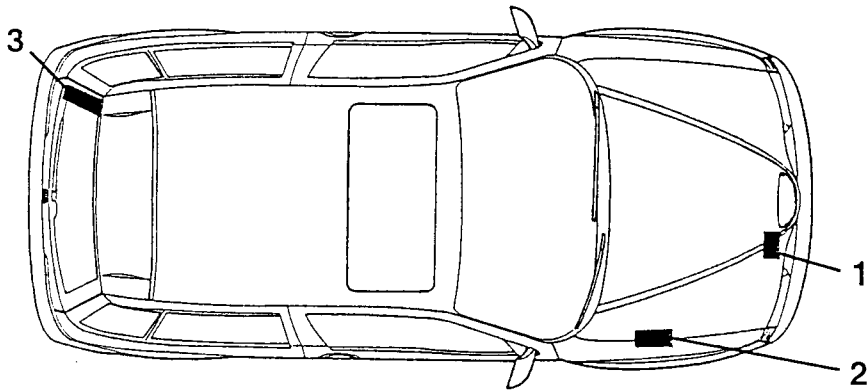

Boxer engines

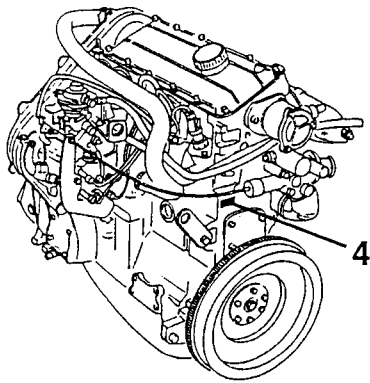

1929 TD engine

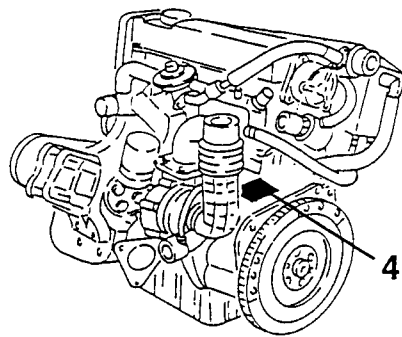

1910 JTD engine

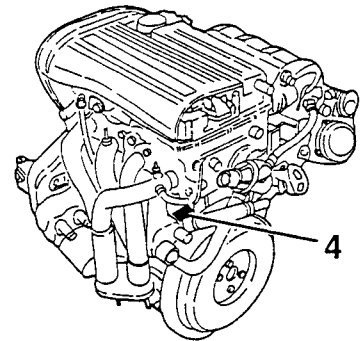

T. Spark 16V engines

- 1. Data plate
- 2. Body code

- 3. Paint identification label
- 4. Engine code

DIMENSIONS

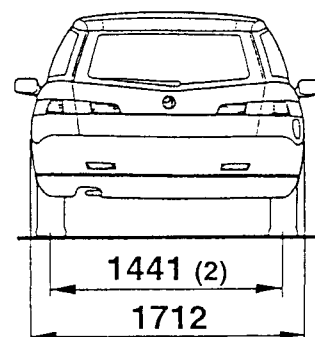
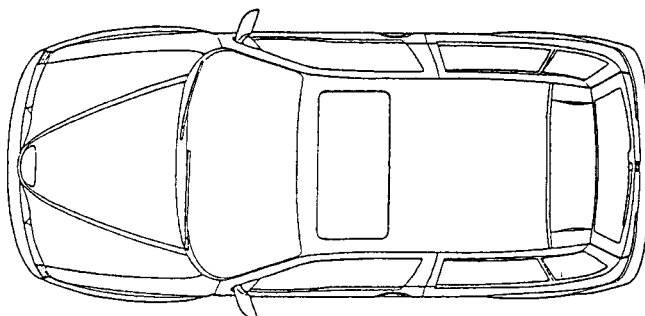
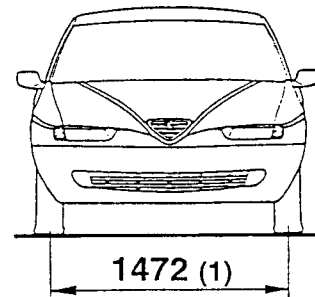
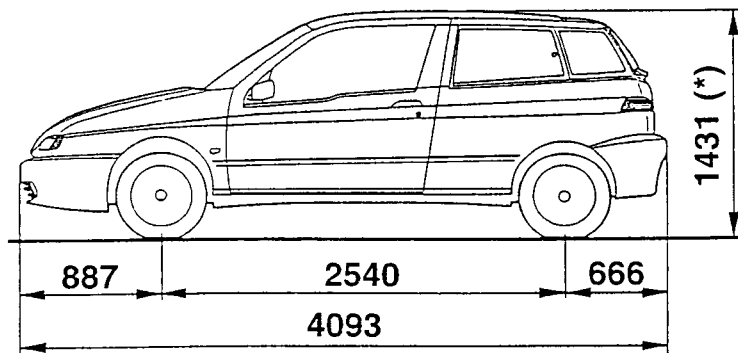

(*): Empty vehicle

(1): 1480 for Turbodiesel versions

(2): 1428 for T. Spark 16V versions

IDENTIFICATION LABEL

This is located on the engine compartment crossmember. It contains the data listed below:

 P O N	A	
	B	
	C	D
	E	Kg
	F	Kg
	1 - G	Kg
	2 - H	Kg
	MOTORE - ENGINE	I
	VERSIONE - VERSION	L
	N° PER RICAMBI N° FOR SPARES	M

- A. Manufacturer
- B. Homologation number
- C. Vehicle identification code
- D. Chassis serial number
- E. Maximum authorized weight of fully loaded vehicle
- F. Maximum authorized weight of fully loaded vehicle plus trailer
- G. Maximum authorized weight on front axle
- H. maximum authorized weight on rear axle
- I. Engine code
- L. Vehicle version code
- M. Number for spare parts
- N. Correct smoke opacity index (for Diesel engine)
- O. Supplier code
- P. Foreign manufacturer

As from the car with chassis no. _____ the new data plate will be used:

 (E)	Alfa Romeo	
	(F)	
	(A)	
	(B)	
	(C)	
	(C)	
	1 - (C)	
	2 - (C)	
	MOTORE - ENGINE	(D)
	VERSIONE - VERSION	(D)
N° PER RICAMBI N° FOR SPARES	(D)	

- A. Space for details of national homologation
- B. Space for punching the consecutive chassis number
- C. Space available for maximum weights authorised by various national laws
- D. Space for versions (for example 930A1) and any supplementary indications to those specified
- E. Space for smoke index
- F. Space for punching manufacturer's name

PAINT IDENTIFICATION LABEL

Verniciatura originale Peinture originale/Original painting Originallackierung/Pintado original	A
Colore/Tinta/Colour Farbton/Color	B
Codice/Code/Codigo	C
PER RITOCCHI E RIVERNICIATURE	D

This is located on the inner part of the luggage compartment and carries the data given below:

- A. Paint manufacturer
- B. Colour name
- C. Colour code
- D. Colour code for touch-up and respray

WEIGHTS AND LOADS

Unit: kg

Weights and loads		Versions		930 A1	930 A4 930 A4A	930 A4B
		930 A3	930 A2 930 A2A			
Kerb weight (without driver)		1140	1140	1190	1210	1200
Maximum allowed weight		1670	1670	1715	1730	1720
Useful load		530	530	525	520	520
Max. permissible weight for axle	front	950	950	950	950	950
	rear	850	850	850	850	900
Towable weight	with braked trailer	1100	1100	1200	1300	1300
	with trailer without brakes	350	350	350	350	350
Carico massimo sulla sfera		50	50	50	50	50

Unit: kg

Weights and loads		Versions		930 A2B 930 A2C	930 A1A
		930 A5	930 A3A		
Kerb weight (without driver)		1240	1135	1165	1195
Maximum allowed weight		1765	1655	1685	1715
Useful load		525	520	520	520
Max. permissible weight for axle	front	950	950	950	950
	rear	900	900	900	900
Towable weight	with braked trailer	1200	1100	1200	1200
	with trailer without brakes	350	350	350	350
Maximum load on tow hook		50	50	50	50

WHEELS AND TYRES

MODEL	SIZES Rim Tyre		PRESSURE (bar)			
			MEDIUM LOAD (2 persons)		FULL LOAD	
			FRONT	REAR	FRONT	REAR
930 A3	Standard item	5 1/2J x 14" 175/65 R14" 82T	2.2	2	2.5	2.5
	Optional item	5 1/2J x 14" 185/60 R14" 82H				
930 A2	Standard item	5 1/2J x 14" 175/65 R14" 82T	2.2	2	2.5	2.5
	Optional item	5 1/2J x 14" 185/60 R14" 82H (*)				
930 A2A	Standard item	5 1/2J x 14" 185/65 R14" 86T	2.2	2	2.5	2.5
930 A1	Standard item	5 1/2J x 14" 185/60 R14" 82H	2.2	2	2.5	2.5
930 A4 930 A4A	Standard item	5 1/2J x 14" 175/65 R14" 82T	2.2	2.1	2.5	2.5
	Optional item	5 1/2J x 14" 185/60 R14" 82H				
930 A4B	Not available at time of going to press					
930 A5	Standard item	6J x 15" 195/55 R15" 84V	2.3	2.1	2.5	2
930 A3A	Standard item	5 1/2J x 14" 185/60 R14" 82H	2.2	2	2.5	2.5
930 A2B	Standard item	5 1/2J x 14" 185/60 R14" 82H	2.2	2	2.5	2.5
930 A2C	Standard item	5 1/2J x 14" 185/60 R14" 82H	2.2	2	2.5	2.5
930 A1A	Standard item	6J x 15" 195/55 R15" 84V	2.2	2	2.5	2.5
ALL	COMPACT SPARE WHEEL 4J x 15" (in steel) - 115/70 R15" 90M 4.00B x 15" (in alloy)		4.2			

(*): Standard item for some Markets.

WARNING: In the event of continuous driving at top speed, the pressures should be increased by 0.3 bar.

FLUIDS AND LUBRICANTS

Type	Group ref.	Application	Classification	Name	
OIL	10 - Engine	Engine (Refilling)	- BOXER - T. SPARK 16V	API SJ SAE 10W/40 ACEA A3-96	SELENIA 20K
			1929 TD 1910 JTD	API CD SAE 10W/40 ACEA B3-96	SELENIA TURBODIESEL SAE 10W/40
	21 - Gearbox	Gearbox - differential (Refilling)	BOXER	API GL5 SAE 80W/90	TUTELA W 90/M - DA
			- 1929 TD - 1910 JTD - T. SPARK 16V	SAE 75W/90 API GL - 5	TUTELA ZC 75 SINT
	50 - Auxiliary organs	Compressor (Refilling)	BOXER	-	SANDEM SP 10 "PAG"
			1929 TD	-	UCON RL - 488
			1910 JTD	-	PAG SP 20
			T. SPARK 16V	-	NIPPONDENSO ND-9
	FLUID	10 - Engine	Cooling circuit (Refilling)	-	ALFA ROMEO CLIMAFLUID SUPER PERMANENT - 40°C
		18 - Clutch	Brake - clutch hydraulic circuit (Refilling)	DOT 4 SAE J 1703 F	ALFA ROMEO BRAKE FLUID SUPER DOT 4
33 - Brakes					
41 - Steering		Power steering system (Refilling)	G.M. DEXRON II	TUTELA GI/A	
50 - Auxiliary organs		Air conditioning system circuit (Refilling)	-	RIVOIRA: SUVA R134a HOECHST-TAZZETTI: FRIGEN R134a ICI-TAZZETTI: KLEA R134a	

(1): For decidedly sportive use of the car fully synthetic **SELENIA Racing 10W/60** engine oil is recommended-

FLUIDS AND LUBRICANTS (Cont.d)

Type	Group ref.	Application	Classification	Name
GREASE	10 - Engine	Housing for intake manifold on water pump	1929 TD	- SIL 133 MOLDGUARD
	18 - Clutch	Thrust bearing seat	BOXER	- TUTELA MR 3
		Thrust bearing seat and clutch control lever shaft	- 1929 TD - T. SPARK 16V	
		Clutch control cylinder prod		
	21 - Gearbox	Pinion taper bearing outer rings and differential carrier	BOXER	- TUTELA MR 3
		Outer surface: - spacer fastening rod to gearshift control lever; - spacer for fastening lever to fork; - guide for gearshift control lever		- TUTELA ZETA 2 ISECO MOLYKOTE LONGTERM N. 2
		Gear engagement rod bushes and gearshift lever ball		- 1929 TD - T. SPARK 16V
	27 - Front axle	Axle shaft constant velocity joints		- OPTIMOL - OLISTAMOLY 2LN 584 MOLYKOTE VN 2461/C TUTELA MRM 2
	33 - Brakes	Pedal unit joints and bushes		- TUTELA ZETA 2
		A.B.S. inductive sensor housing		
41 - Steering	Roller bush housing on steering column support		- SPCA SPAGRAPH ISECO ERGON RUBBER GREASE REINACH SFERUL B2 AR	
44 - Suspensions and wheels	Wishbone flexible mounts		- GREASE MOLYKOTE 7544 PG54 TUTELA MR3	
	Steering track rods		- MOLYGUARD SYL 113	

APPROXIMATE SERVICING CAPACITIES

Version		930 A3	930 A2 930 A2A	930 A1	930 A4 930 A4A	930 A4B	930 A5	930 A3A 930 A2B 930 A2C 930 A1A
		Capacity						
Fuel tank		51 litres			51/61 litres (*)			
Fuel reserve		5 + 8 litres						
Engine oil	Total capacity: sump + filter + wells + radiator	4.7 litres	5.2 litres	6 litres	(**)	5.0 litres		
	Sump + filter (for periodical replacement)	4 litres	4.5 litres	5 litres	4.2 litres	4.4 litres		
Gearbox - differential oil		2.4 litres		2 litres		2 litres		
Power steering system oil		1.1 litres			(**)	1.3 litres		
Brake and clutch circuit oil		0.4 kg		0.5 kg	(**)	0.5 kg		
Engine cooling system fluid		7.8 litres		8.9 litres	(**)	8.3 litres	8.4 litres	
Conditioner compressor oil		240 ± 15 cm ³		236 ± 15 cm ³	130 g	150 ± 20 cm ³		
Air conditioner system fluid		0.700 kg			(**)	0.700 kg		

(*): For Versions/Markets

(**): Not available at time of going to press.

CAR LIFTING POINTS

Using an arm lift or workshop jack.

- The car should be raised setting the ends of the arms or the jack in the areas illustrated.

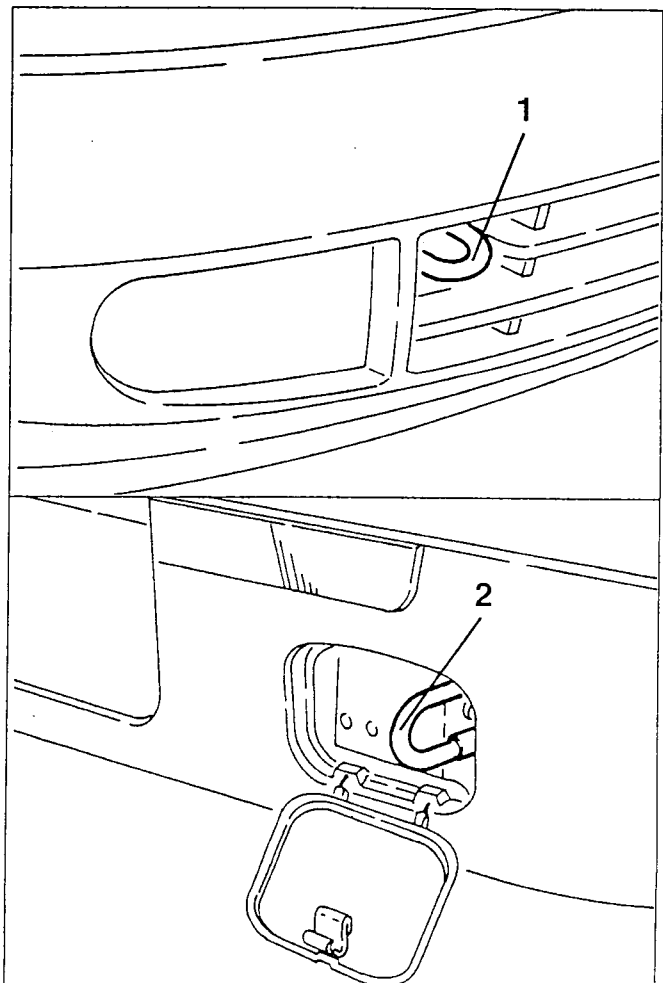
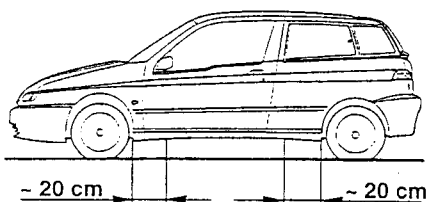

1. Front tow hook

2. Rear tow hook

CAR TOW POINTS

The car has two rings, one at the front and one at the rear, on the right-hand side of the bumpers.

The rear ring is covered by a lid that is opened by pushing on the edge.

Always strictly adhere to local regulations on the subject of towing.

Before towing, the ignition switch of the towed car should be turned to MAR and then to STOP without removing it; this will prevent the steering from locking.

Remember that when the car is towed, the vacuum is not created in the servobrake system, therefore, considerably greater pressure on the brake pedal is required.