

AIRBAG + SIDEBAG

INDEX

| | |
|-------------------------------------|--------|
| GENERAL DESCRIPTION | 27A-2 |
| SAFETY REGULATIONS | 27A-3 |
| WIRING DIAGRAM | 27A-4 |
| FUNCTIONAL DESCRIPTION | 27A-5 |
| COMPONENTS AND CONNECTORS | 27A-6 |
| LOCATION OF COMPONENTS | 27A-9 |
| TROUBLESHOOTING | 27A-10 |

GENERAL DESCRIPTION

The car has a safety system complete with:

- Airbag for frontal protection of driver and passenger.
- Side airbags

The system actuates:

- the airbags on the driver and passenger side in case of **frontal collision** of a certain severity.
- In the case of a **side collision** of a certain severity, the side airbag on the collision side alone is actuated.

The system is made up of the following components:

- ECU
- Driver's side airbag
- Passenger's side airbag
- Sensor for automatic disabling of passenger's side airbag (only present up to June '99)
- Side collision sensor on left doorjamb
- Side collision sensor on right doorjamb
- Right side airbag
- Left side airbag
- Diagnostics socket for checking the system with Examiner or other diagnostics instruments

ECU

An ECU manages the entire system by controlling all the components and activating, when necessary, all the restraint systems (pretensioners and airbags).

Operation in the case of frontal collisions

The ECU contains an accelerometric sensor whose signal, appropriately processed by a microprocessor, detects the severity of a collision, and consequently decides to activate the airbag.

The second sensor has safety functions and consents to activation of the airbags. **The ECU detects only front collisions. It does not intervene whatsoever in cases of side collisions, rear collisions or rollovers.**

Operation in the case of side collisions

On the doorjamb of the front doors there is an accelerometric sensor that detects side collisions and transmits a signal to the control unit.

This signal, appropriately processed by a microprocessor inside the ECU, detects the severity of the side collision and consequently decides whether or not to activate the side airbag on the collision side, but only if the safety sensor consents to activation.

Activations of the side airbags are independent from one another and from the frontal airbags.

SIDE AIRBAGS

Collision sensors

On the doorjamb of the two front doors is an accelerometric sensor which, in the case of side collisions, transmits a signal to the control unit.

This signal is appropriately processed inside the control unit, which consequently decides whether or not to activate the side airbag on the side collision where the impact was detected.

In fact, the control unit has a second safety sensor which detects side collisions (much like the sensor that detects frontal collisions) and consents to activation of the side airbag on the side of the collision.

This sensor is positioned so as to detect impacts only on the side on which it is located: e.g.: the sensor on the driver's side doorjamb detects only collisions on the left and not from the upper right side.

NOTE: The sensor must always be mounted with the arrow pointing towards the front of the vehicle.

Side airbag

The side airbag is housed on the external part – toward the window – of both front seats.

It consists of a container – built into the seat back – that houses the gas generator and the folded bag.

The container is fixed to the frame of the seat back by means of a bracket.

The gas generator can be activated electrically by means of a signal from the ECU, whereby a charge of propellant is fired and releases a compressed gas (Argon) which expands in the cushion. The side cushions are smaller than the front cushions.

Cushion deflation – after being inflated by the gas – is immediate, thanks to a hole located on the rear part of it.

The seat upholstery has seams with predetermined breakage lines which allow the complete release of the cushion.

Disabling the passenger's side airbag (only present up to June '99)

If a "passenger absent" condition is detected continuously for at least 30 seconds, the control unit cuts out the activation of both the frontal and side airbag on the passenger's side.

If the sensor later detects the "passenger present" condition, the control unit immediately re-enables the passenger airbags.

SAFETY REGULATIONS TO OBSERVE FOR INTERVENTIONS ON CARS FITTED WITH THE AIRBAG



SYSTEM

Below is a list of regulations that **MUST ABSOLUTELY BE OBEYED** in case of any sort of intervention on cars equipped with the airbag safety system.

See description in section 55-27 above.

WIRING DIAGRAM

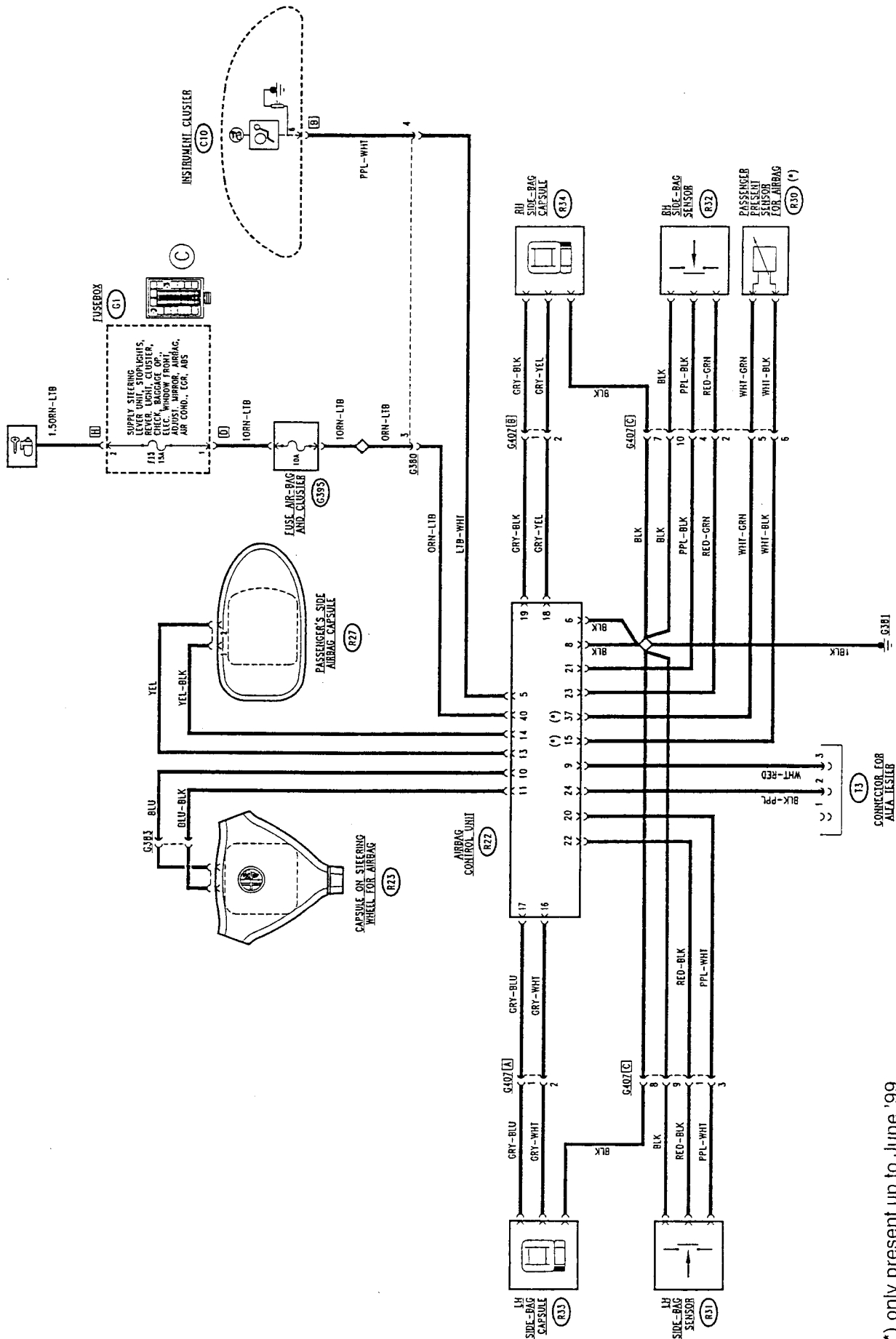

(**) only present up to June '99

FUNCTIONAL DESCRIPTION

The **R22** control unit is protection-powered, (circuit protected by fuse **F15** located in fuse box **G1**) by pin 40.

The power supply of the **R22** control unit is protected by another fuse (**G395**) located in the vicinity of the same fuse box (**G1**).

The system contains two frontal cushions: one is positioned on the driver's side **R23** (in the center of the steering wheel) and one in the dashboard in front of the passenger **R27**. It contains two side cushions: **R32** e **R33**.

NOTE: The cushion on the steering wheel is connected electrically by means of a spiraled cable and the connector **G383**.

While the car is traveling, control unit **R22** continuously runs system diagnostics to check the continuity of system circuits and components.

In case of a frontal collision detected by the two internal sensors (one piezoelectric and the other mechanical), the control unit, activates both modules by sending a voltage by means of two signals at 12V: one earth signal and one power supply signal, pin 13 and 14 for the passenger module **R27** and pin 10 and 11 for the module on the steering wheel **R23**.

If the sensor **R30** (only present up to June '99) indicates (pin 15 and 37 of **R22**) the absence of the passenger on the seat, the relative airbag is not activated.

In the case of a side collision, the information is sent to the control unit by sensors **R31** (driver's side) and **R32** (passenger's side) on pins 20 and 22 and 21 and 23 of **R22** respectively.

Consequently the control unit enables the side bag on the driver's side **R33** (from pins 16 and 17) and the side bag on the passenger's side **R34** (from pins 18 and 19).

The telltale light in question is the so-called "intelligent" type: in fact it lights up not only when the system detects an anomaly, but also in cases of a lack of connection or short circuit to earth from the circuit that connects the telltale light to the relative control unit, thanks to a special internal pilot circuit which checks proper connection.

Upon detection of a failure or malfunction of the system, the type of failure is memorized and consequently the airbag telltale light on the instrument panel **C10** turns on to warn the user that there is a failure in the system.

Finally, connection **T3** allows connection to the ALFA TESTER (pin 24).

CONTROL UNIT PIN-OUT

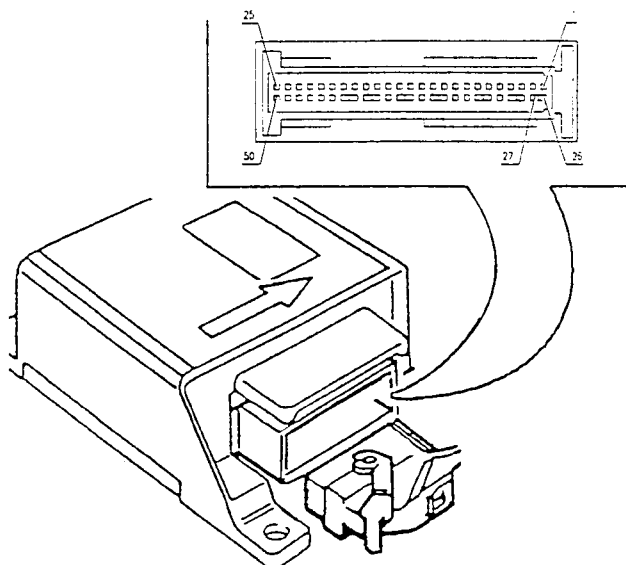

5. Airbag system failure warning light signal
6. Earth
8. Earth
9. K diagnostics line
10. Activation (+) driver's frontal airbag
11. Activation (-) driver's frontal airbag
13. Activation (+) passenger's frontal airbag
14. Activation (-) passenger's frontal airbag
15. Passenger presence sensor signal
16. Activation (+) driver's side airbag
17. Activation (-) driver's side airbag
18. Activation (+) passenger's side airbag
19. Activation (-) passenger's side airbag
20. Driver's seat side sensor
21. Passenger's seat side sensor
22. Driver's seat side sensor power supply
23. Passenger's seat side sensor power supply
24. Diagnostics K line earth
37. Passenger presence sensor signal
40. Protected power supply

COMPONENTS AND CONNECTORS

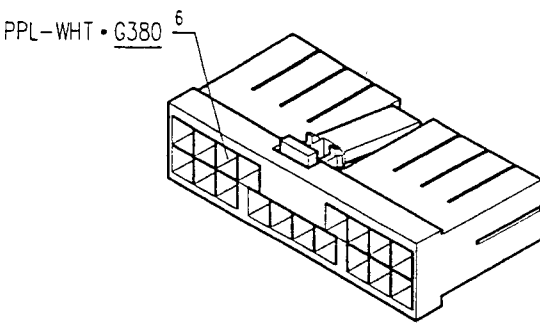
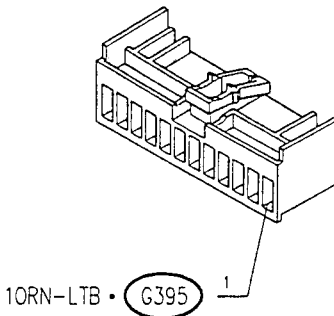
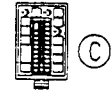
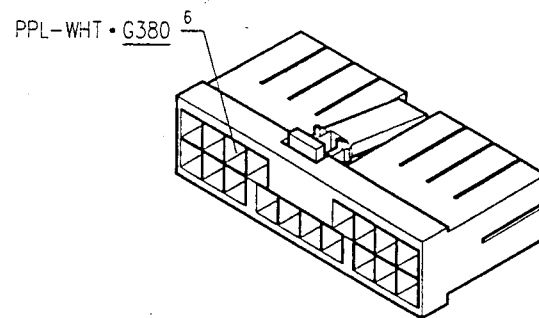
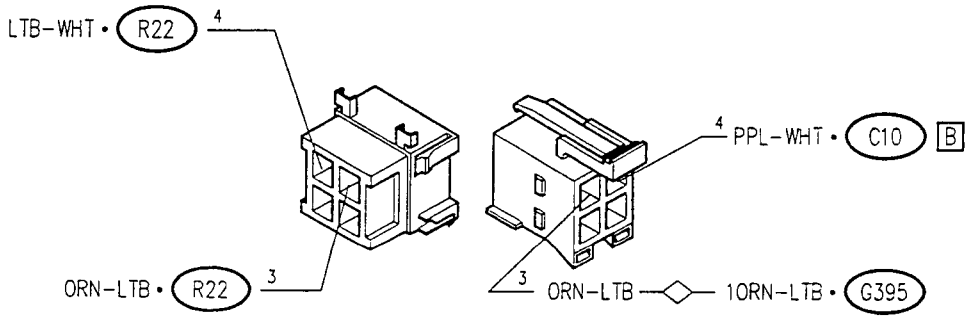
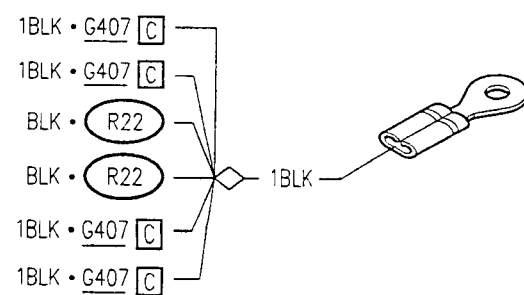
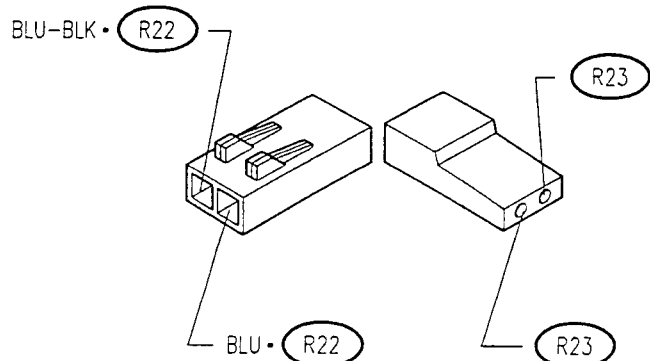
| | | | |
|--|-------|--|---|
| Instrument cluster | C10 B | Fusebox | G1 D |
|  | |  |  |
| Fusebox | | G1 H | |
|  | | | |
| Airbag connector | | | G380 |
|  | | | |
| Earth for airbag | G381 | Connector for airbag capsule | G383 |
|  | |  | |

COMPONENTS AND CONNECTORS (cont.d)

| | | | |
|--|-------------|-------------------|----------------------|
| Air Bag and cluster fuse | G395 | Seam for Side Bag | G407 A |
| | | | |
| Seam for Side Bag | | | G407 B |
| | | | |
| Seam for Side Bag | | | G407 C |
| | | | |
| Airbag control unit | | | R22 |
| <ul style="list-style-type: none"> 5 ORN-LTB • G380 6 BLK ◇ 1BLK • G381 8 BLK ◇ 1BLK • G381 9 WHT-RED • T3 10 BLU • G383 11 BLU-BLK • G383 13 YEL • R27 14 YEL-BLK • R27 15 WHT-BLK • G407 C (*) 16 GRY-WHT • G407 A 17 GRY-BLU • G407 A 18 GRY-YEL • G407 B 19 GRY-BLK • G407 B 20 PPL-WHT • G407 C 21 PPL-BLK • G407 C 22 RED-BLK • G407 C | | | |

(*) only present up to June '99
PA49300000013

COMPONENTS AND CONNECTORS (cont.d)

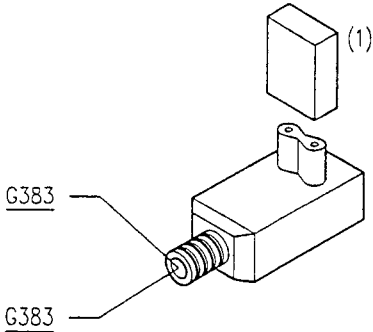
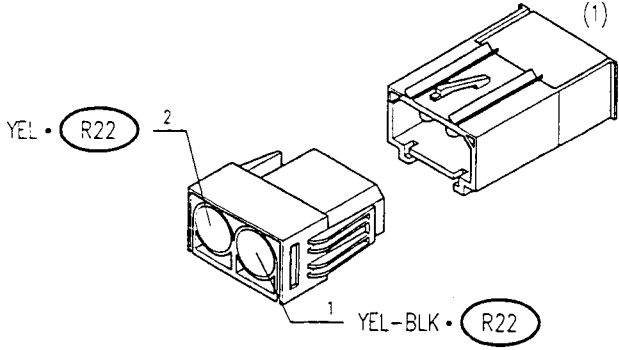
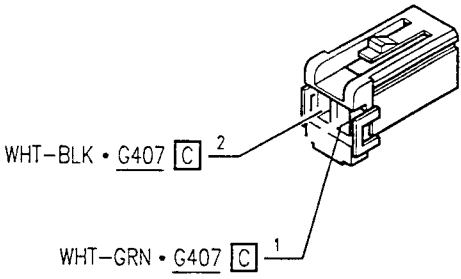
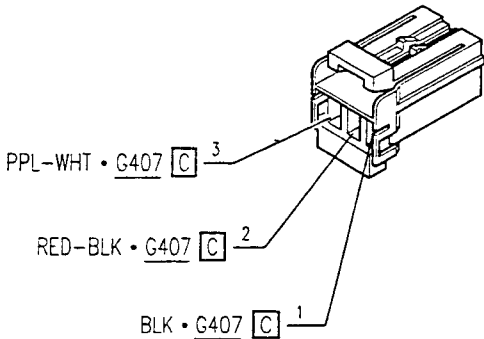
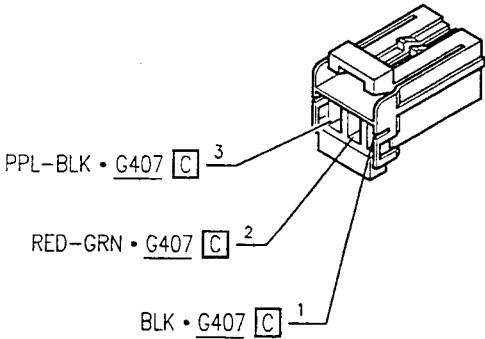
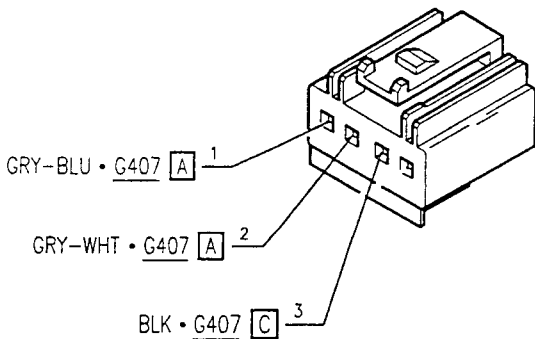
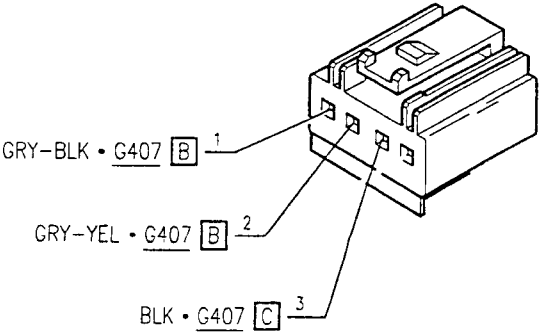
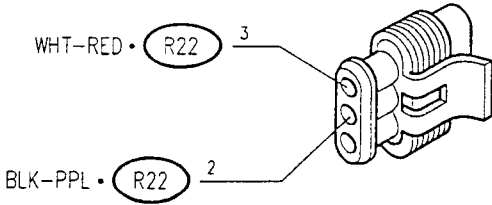
| | | | |
|---|------------|---|------------|
| <p>Capsule on steering wheel for airbag</p> | <p>R23</p> | <p>Passenger's side airbag capsule</p> | <p>R27</p> |
|  <p>Diagram showing the capsule on steering wheel for airbag. Two wires are connected to the connector, both labeled G383. A small rectangular component (1) is shown above the connector.</p> | |  <p>Diagram showing the passenger's side airbag capsule. Two wires are connected to the connector: one labeled YEL • R22 (2) and the other labeled YEL-BLK • R22 (1). A small rectangular component (1) is shown above the connector.</p> | |
| <p>Passenger present sensor for Air Bag (*)</p> | <p>R30</p> | <p>LH Side Bag sensor</p> | <p>R31</p> |
|  <p>Diagram showing the passenger present sensor for Air Bag. Two wires are connected to the connector: one labeled WHT-BLK • G407 [C] (2) and the other labeled WHT-GRN • G407 [C] (1).</p> | |  <p>Diagram showing the LH Side Bag sensor. Three wires are connected to the connector: one labeled PPL-WHT • G407 [C] (3), one labeled RED-BLK • G407 [C] (2), and one labeled BLK • G407 [C] (1).</p> | |
| <p>RH Side Bag sensor</p> | <p>R32</p> | <p>LH Side Bag capsule</p> | <p>R33</p> |
|  <p>Diagram showing the RH Side Bag sensor. Three wires are connected to the connector: one labeled PPL-BLK • G407 [C] (3), one labeled RED-GRN • G407 [C] (2), and one labeled BLK • G407 [C] (1).</p> | |  <p>Diagram showing the LH Side Bag capsule. Three wires are connected to the connector: one labeled GRY-BLU • G407 [A] (1), one labeled GRY-WHT • G407 [A] (2), and one labeled BLK • G407 [C] (3).</p> | |
| <p>RH Side Bag capsule</p> | <p>R34</p> | <p>Connector for ALFA TESTER (airbag)</p> | <p>T3</p> |
|  <p>Diagram showing the RH Side Bag capsule. Three wires are connected to the connector: one labeled GRY-BLK • G407 [B] (1), one labeled GRY-YEL • G407 [B] (2), and one labeled BLK • G407 [C] (3).</p> | |  <p>Diagram showing the connector for ALFA TESTER (airbag). Two wires are connected to the connector: one labeled WHT-RED • R22 (3) and the other labeled BLK-PPL • R22 (2).</p> | |

(*) only present up to June '99
PA49300000013

LOCATION OF COMPONENTS

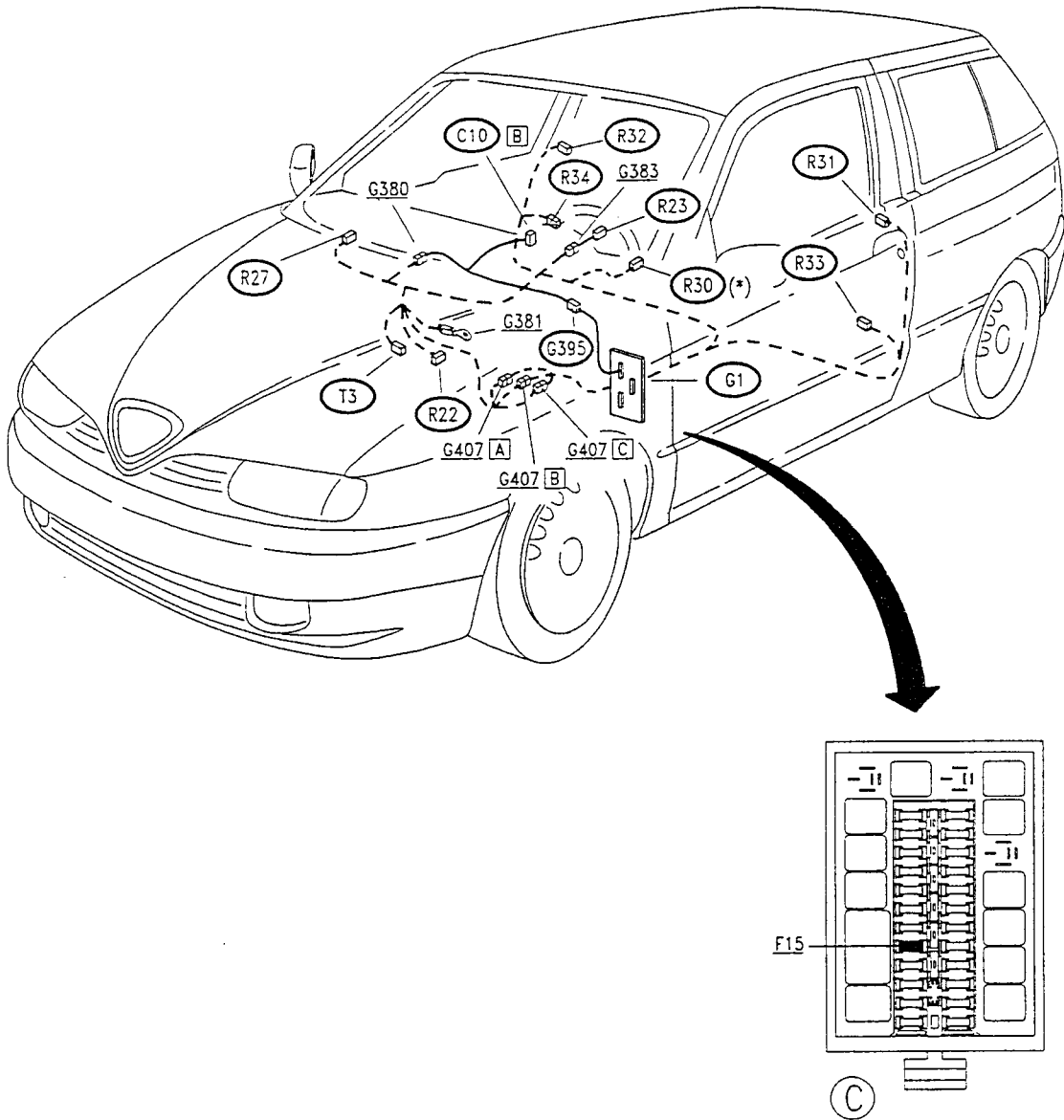

(●) Red fuse box

NOTE:

— · — · — The airbag wiring harness is easy to recognize because the sheath is **YELLOW**

(*) only present up to June '99

TROUBLESHOOTING

**WARNING:**

Before any intervention on system components, carefully read the **SAFETY REGULATIONS** listed above and follow them scrupulously.

System self-diagnosis

During the entire traveling period of the car, the ECU runs a self-diagnostics test to check the airbag system and memorize any failures. When a failure is detected, it not only memorizes it but it turns on the airbag warning light.

Upon starting the car, the airbag warning light turns on for about 4 seconds (initial test phase) and then turns off.

If the light **DOES NOT** turn on or **DOES NOT** turn off after 4 seconds, there is a failure in the airbag system.

The anomalies memorized in the control unit can be cancelled, after the failure has been repaired by means of diagnostic instruments (e.g. Examiner).

The control unit also memorizes airbag activations caused by particularly severe collisions. **When a collision causes activation of the system, it is not possible to delete it from the memory of the control unit and therefore the control unit must always be replaced.**

System diagnostics

It is possible to analyze anomalies memorized in the control unit by means of diagnostic instruments (e.g. Examiner).

During diagnosis, in particular if it is necessary to take measurements of continuity on the module lines, it is **absolutely necessary to disconnect the modules from the wiring harness and replace them with the appropriate simulation resistances.**



IT IS PROHIBITED TO TAKE CONTINUITY MEASUREMENTS ON SYSTEM COMPONENTS UNLESS THE MODULES HAVE BEEN REPLACED WITH THE SIMULATION RESISTANCES.