

HIGH AND LOW BEAM HEADLAMPS

INDEX

WIRING DIAGRAM	6-2
GENERAL DESCRIPTION	6-3
FUNCTIONAL DESCRIPTION	6-3
COMPONENTS AND CONNECTORS	6-4
LOCATION OF COMPONENTS	6-7
FAULTFINDING TABLE	6-8

WIRING DIAGRAM

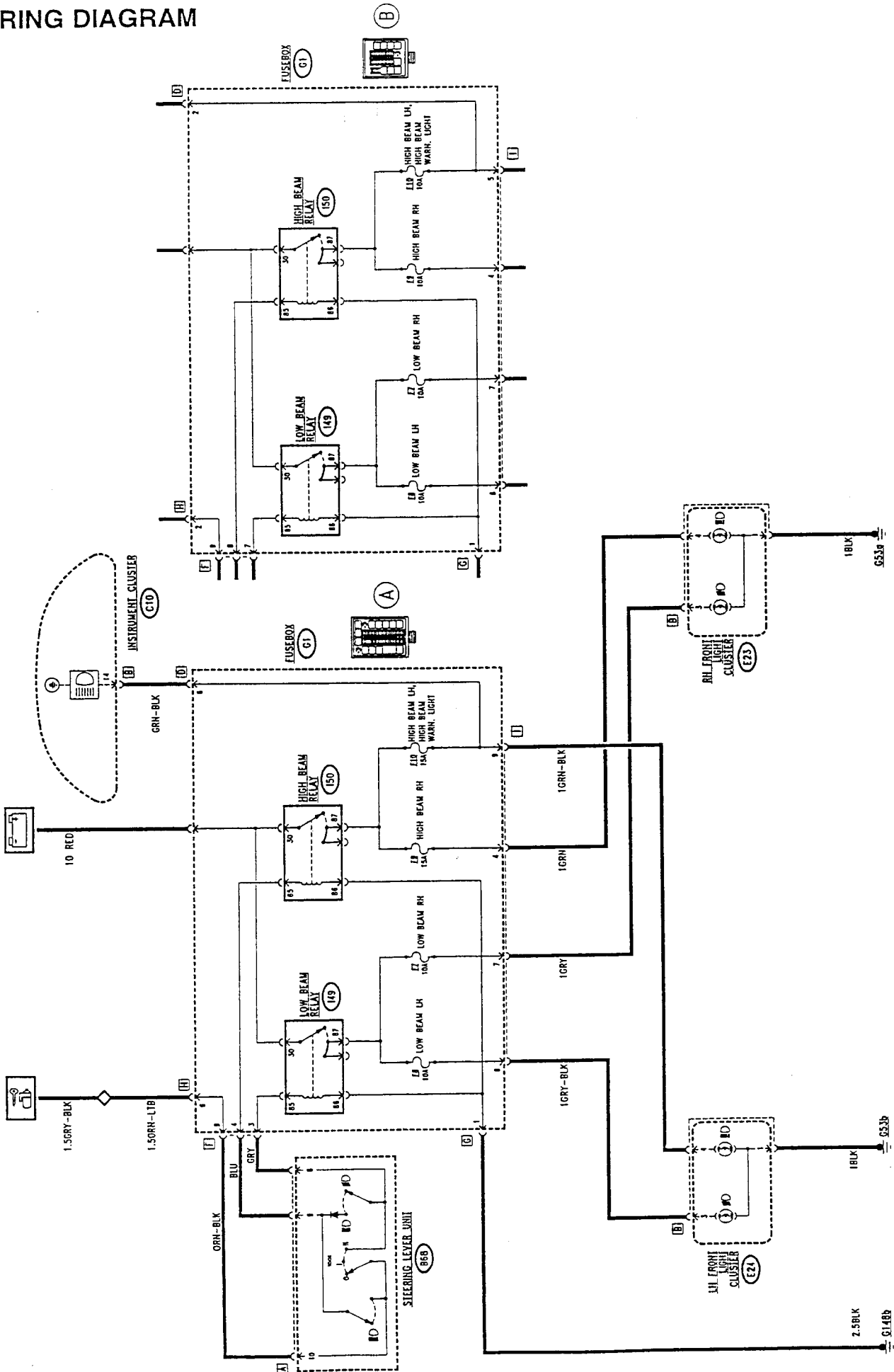

GENERAL DESCRIPTION

The car is fitted with two separate lamps for the low beams and two for the high beams.

The low beams are turned on by the switch on the steering column lever unit one position on from the sidelights; from this position the high beam can be permanently selected operating the high/low beam switch; lightly pulling the lever towards the steering wheel activates the high beam "flashing" function for as long as the lever is pulled.

A warning light on the dashboard indicates when the high beams are on.

For safety reasons each single high and low beam lamp is protected by a fuse.

NOTE: some versions are equipped with an electrically-operated headlamp aiming device (see "Headlamp aiming device"); however a manual device enables quick and simple adjustment of the beam to the loading conditions of the vehicle.

FUNCTIONAL DESCRIPTION

The circuit of the low beam headlamps is operated by relay switch I49 located in fusebox G1.

Moving the lever unit switch B68 to position II and with the switch in the low beam position the coil of relay switch I49 is "turn key" supplied thereby closing the circuit supplying the left headlamp E24 and the right headlamp E23.

Each circuit is protected by a fuse in fusebox G1: F7 for the right headlamp and F8 for the left one.

Fusebox G1 "C" contains fuse F15 which protects the services of the steering column lever unit B68.

The high beam circuit is operated by relay switch I50 located in fuse box G1.

Moving the switch to the high beam position with the lever unit switch B68 on position II, or closing the "flashing" contact, the coil of relay switch I50 is "turn key" supplied thereby closing the circuit that supplies the left headlamp E24 and the right one E23. Each circuit is protected by a fuse in fusebox G1: F9 for the right headlamp and F10 for the left one.

The left high beam headlamp supply line also sends a signal to the instrument panel C10 to turn on the high beam on warning light.

COMPONENTS AND CONNECTORS

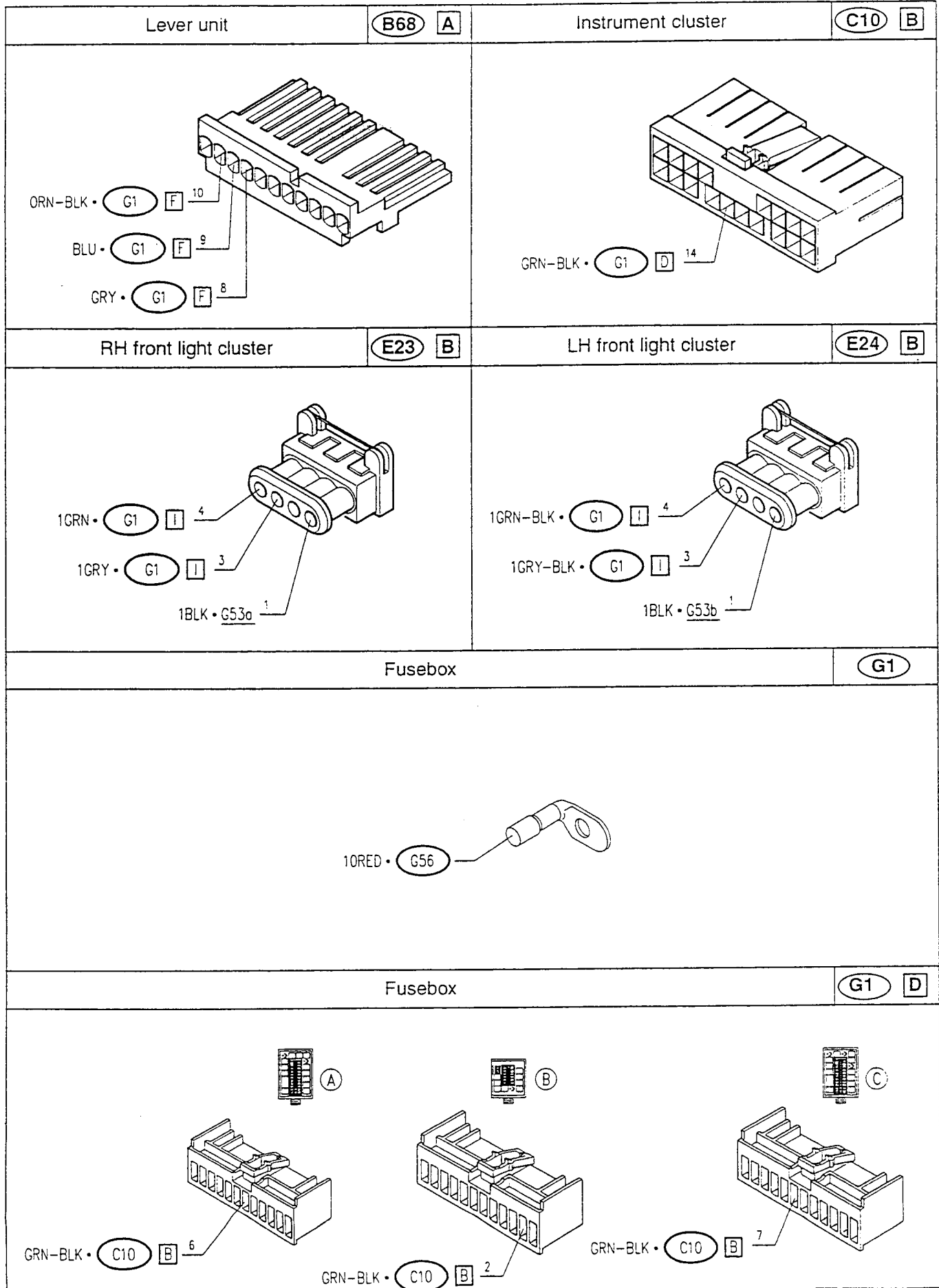

COMPONENTS AND CONNECTORS (cont.d)

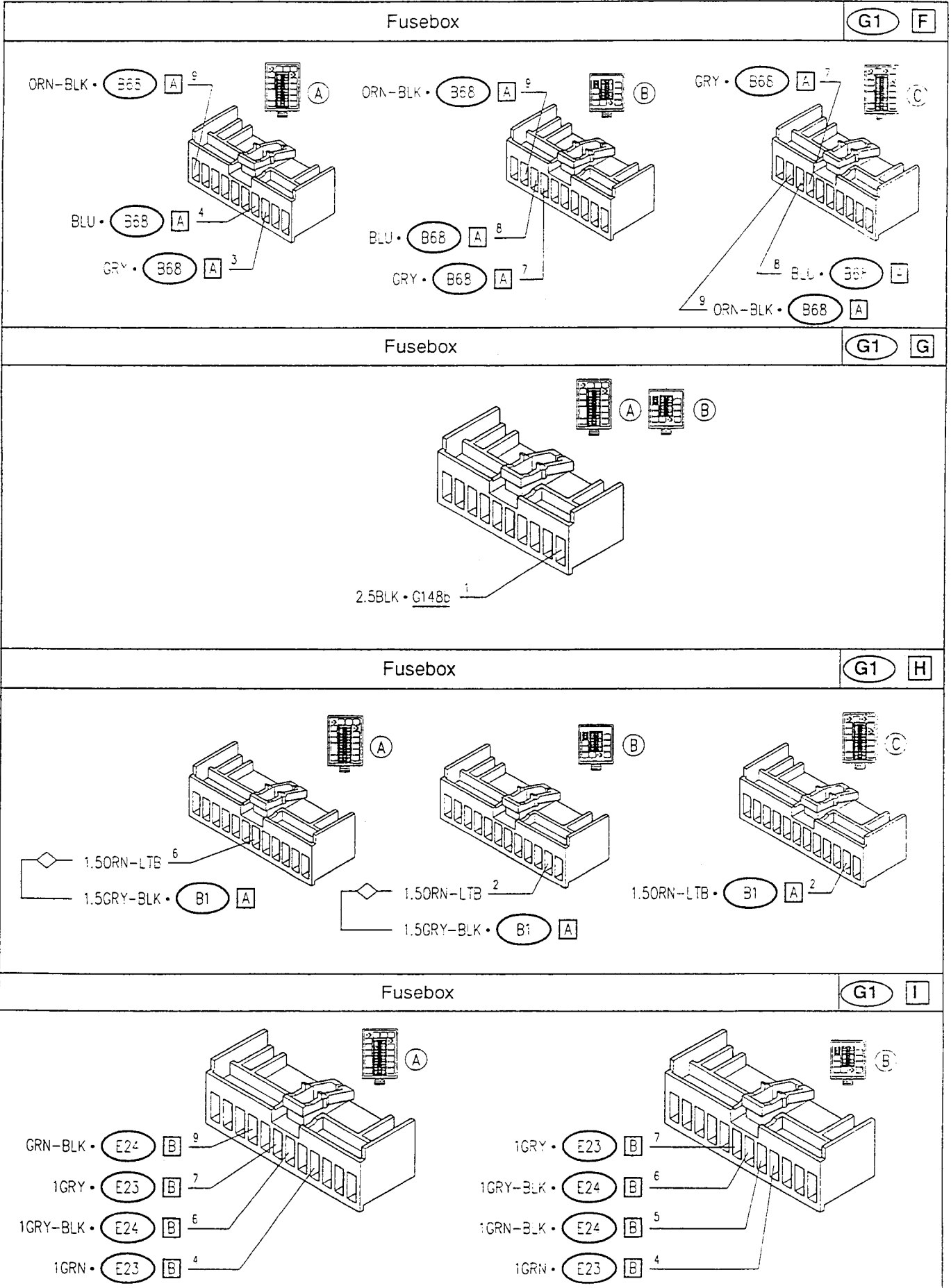

COMPONENTS AND CONNECTORS (cont.d)

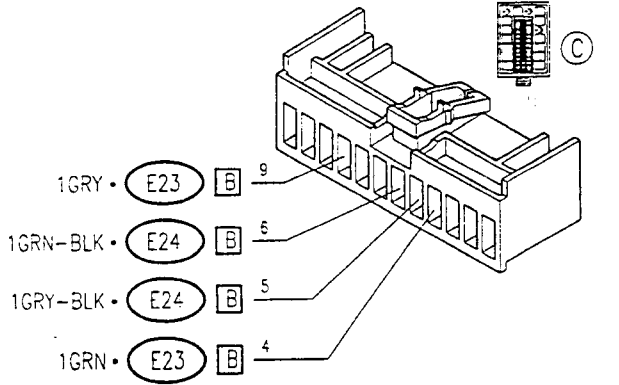
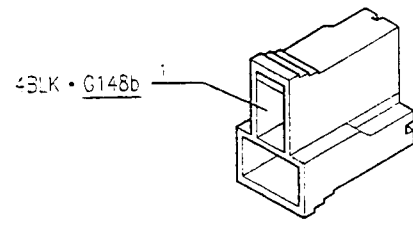
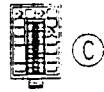
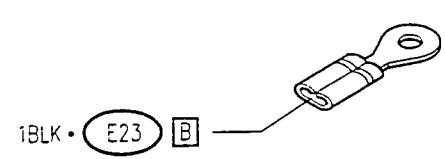
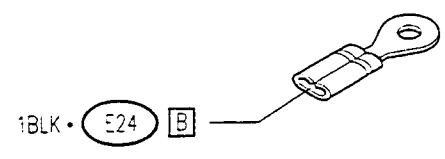
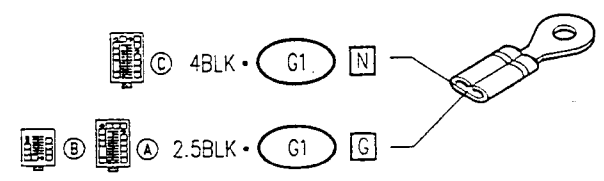
Fusebox	G1 I	Fusebox	G1 N
 <p>1GRY • E23 (B) 9</p> <p>1GRN-BLK • E24 (B) 6</p> <p>1GRY-BLK • E24 (B) 5</p> <p>1GRN • E23 (B) 4</p>	 <p>4BLK • G148b 1</p>	 <p>C</p>	
RH side engine comp. earth	G53a	RH side engine comp. earth	G53b
 <p>1BLK • E23 (B)</p>	 <p>1BLK • E24 (B)</p>		
LH earth under dashboard			G148b
 <p>4BLK • G1 (N)</p> <p>2.5BLK • G1 (G)</p> <p>A B</p>			

LOCATION OF COMPONENTS

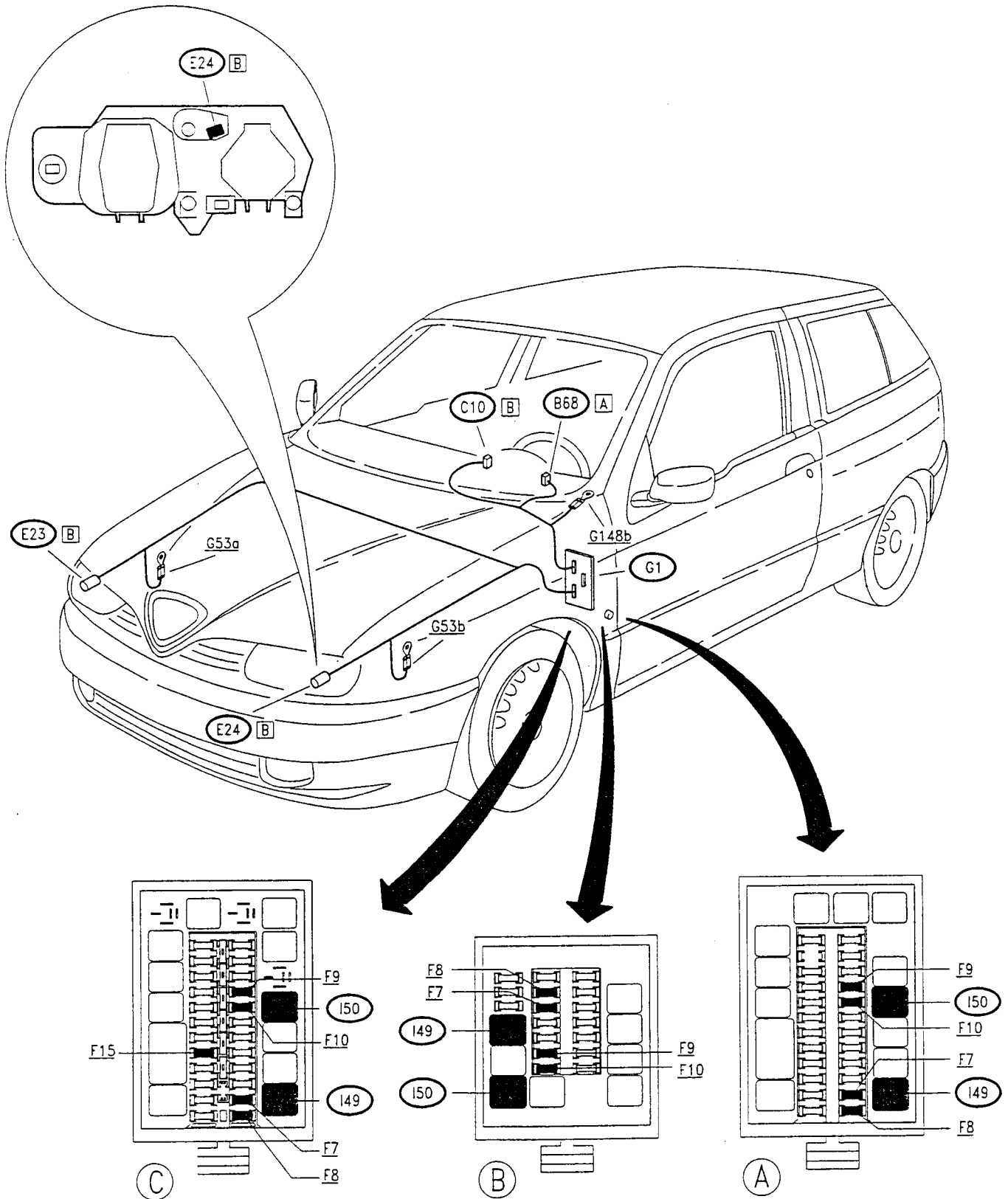

FAULTFINDING TABLE

Failure	Component to be checked									
	F7	F8	F9	F10	E23	E24	I49	I50	B68	C10 (*)
Both low beam lamps							•		•	
RH low beam lamp	•				•					
LH low beam lamp		•				•				
Both high beam lamps								•	•	
RH high beam lamp			•		•					
LH high beam lamp				•		•				
High beam warning light				•						•

(*) **WARNING:** the high beam warning light of the instrument cluster **C10** is replaceable, as it is a bulb and not a led.

Up to M.Y. '98

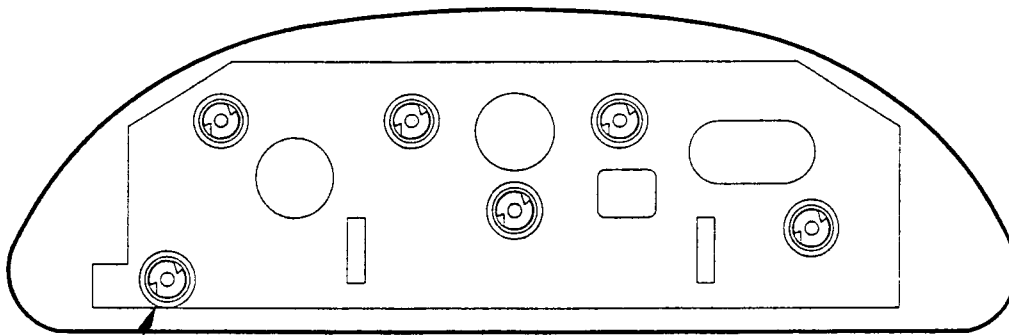

From M.Y. '99

