

# STARTING AND CHARGING

## INDEX

GENERAL DESCRIPTION . . . . .	4-2
WIRING DIAGRAM (Boxer versions) . . . . .	4-3
FUNCTIONAL DESCRIPTION (Boxer versions) . . . . .	4-4
COMPONENTS AND CONNECTORS (Boxer versions) . . . . .	4-4
LOCATION OF COMPONENTS (Boxer versions) . . . . .	4-7
WIRING DIAGRAM (TD version) . . . . .	4-8
WIRING DIAGRAM (TD-CAT version) . . . . .	4-9/1
FUNCTIONAL DESCRIPTION (TD, TD-CAT version) . . . . .	4-9/2
COMPONENTS AND CONNECTORS (TD, TD-CAT version) . . . . .	4-10
LOCATION OF COMPONENTS (TD version) . . . . .	4-12/2
LOCATION OF COMPONENTS (TD-CAT version) . . . . .	4-13
WIRING DIAGRAM (T.SPARK version) . . . . .	4-14
FUNCTIONAL DESCRIPTION (T.SPARK version) . . . . .	4-15
COMPONENTS AND CONNECTORS (T.SPARK version) . . . . .	4-15
LOCATION OF COMPONENTS (T.SPARK version) . . . . .	4-17
WIRING DIAGRAM (JTD version) . . . . .	4-18
FUNCTIONAL DESCRIPTION (JTD version) . . . . .	4-19
COMPONENTS AND CONNECTORS (JTD version) . . . . .	4-19
LOCATION OF COMPONENTS (JTD version) . . . . .	4-21
FAULT-FINDING TABLE . . . . .	4-21
CHECKING COMPONENTS . . . . .	4-22

## GENERAL DESCRIPTION

The starting and charging circuit comprises the battery, starter motor and the alternator.

The **battery** (12V) is sealed and maintenance-free.

The **starter motor** comprises a direct current motor supplied by the battery and a control and engagement solenoid.

By turning the ignition key, the voltage leading from the battery supplies the windings of the motor, generating the electromagnetic forces which turn the pinion of the motor itself: simultaneously, the solenoid is energized which operates the mechanism engaging the pinion in the flywheel ring gear, thereby setting the crankshaft into rotation.

The **alternator** recharges the battery during the normal rotation of the engine: the alternator shaft (rotor) turned directly by the crankshaft through a belt is supplied with the excitation current and generates a magnetic field which induces an alternate current on

the fixed winding (stator); this is transformed into direct current by a rectifier bridge with diodes and sent to recharge the battery.

A voltage regulator built into the alternator makes it possible to maintain a constant voltage supply (appr. 12 V) for all the fields of load changes and engine speed.

In the versions **without ALFA ROMEO CODE but with anti-theft system**, the supply to the starter motor receives the necessary consent from the anti-theft control unit, which then operates the starting consent relay, thus also the motor itself.

In the event of an "alarm" the motor is not supplied and the engine cannot be started using the key.

In the versions **with ALFA ROMEO CODE** the starter motor is **NOT** inhibited, but only the engine (see the "ALFA ROMEO CODE" section).

## WIRING DIAGRAM (Boxer versions)

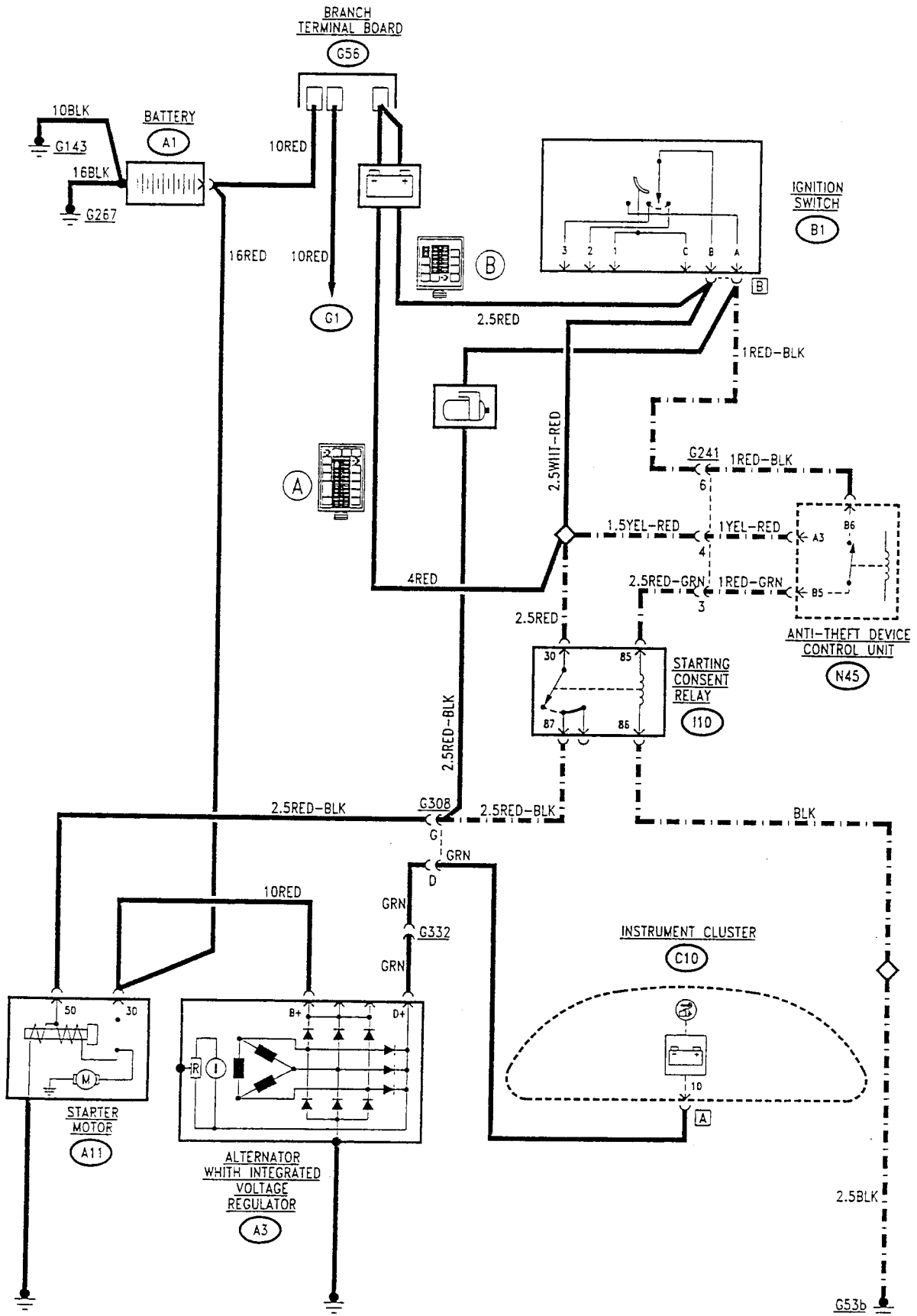

----- variant for cars without ALFA ROMEO CODE, but with anti-theft system

## FUNCTIONAL DESCRIPTION (Boxer versions)

When the ignition key is turned in the ignition switch **B1** right round to the "STARTING" position, the windings of the solenoid (pin 50) of the starter motor **A11** are energized and the actual motor is supplied (pin 30) with the voltage leading from the battery **A1** in this way cranking the engine ( In cars without ALFA ROMEO CODE, the starter motor supply "crosses" the anti-theft control unit **N45** (pin B5 - B6) which cuts off this supply in the event of an alarm and the starting consent relay **I10**).

When the engine is running, the direct current generated by the alternator **A3** (pin B+) is sent via the starter motor **A11**, to recharge the battery **A1**.

All the lines for supplying the various electric systems of the car branch from the terminal board **G56**, connected to the + post of the battery **A1** (see "Power Supply").



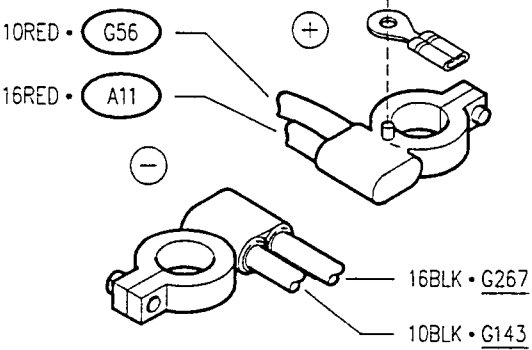
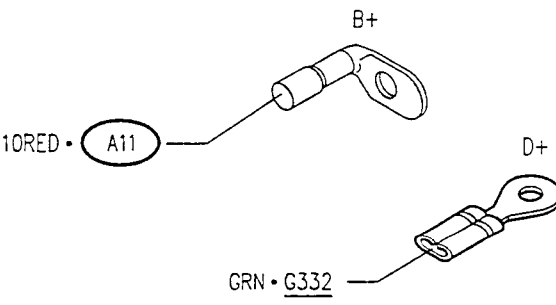
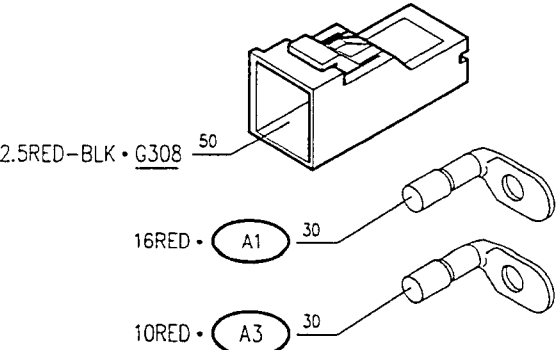
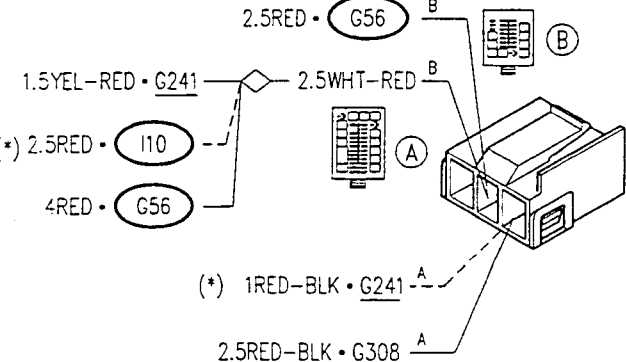

When the alternator is not turning and therefore not charging the battery, an earth signal is sent from pin D+ to the instrument cluster **C10** to turn on the corresponding warning light; once the engine has started this signal becomes 12 V and the warning light goes off.

## COMPONENTS AND CONNECTORS (Boxer versions)

Battery	<b>A1</b>	Alternator, with built-in voltage regulator	<b>A3</b>
			
Starter motor	<b>A11</b>	Ignition switch	<b>B1</b> <b>B</b>
			

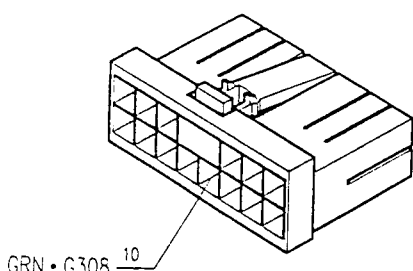
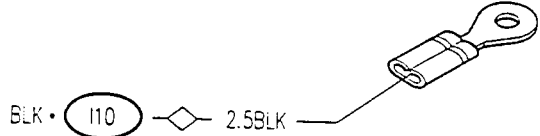
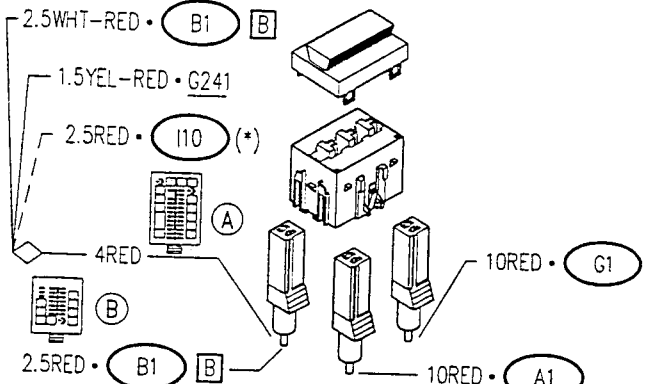
(\*) Variant for cars without ALFA ROMEO CODE, but with anti-theft system

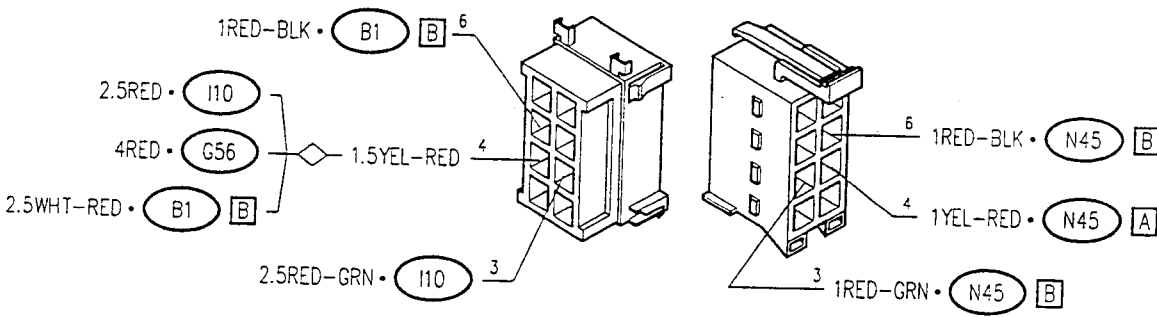
### COMPONENTS AND CONNECTORS (cont.d)

Instrument cluster	C10 A	LH engine compartment earth(*)	G53b
 <p>GRN • G308 10</p>		 <p>BLK • I10 2.5BLK</p>	
Branch terminal board	G56	Centre services tray earth	G143
 <p>2.5WHT-RED • B1 B 1.5YEL-RED • G241 2.5RED • I10 (*) 4RED • A 10RED • G1 2.5RED • B1 B 10RED • A1</p>		 <p>10BLK • A1</p>	
Anti-theft device wiring connector (*)			G241
 <p>1RED-BLK • B1 B 6 2.5RED • I10 4RED • G56 2.5WHT-RED • B1 B 2.5RED-GRN • I10 3 1.5YEL-RED 4 1RED-BLK • N45 B 6 1YEL-RED • N45 A 4 1RED-GRN • N45 B 3</p>			
Earth on crankcase			G267
 <p>16BLK • A1</p>			

(\*) Variant for cars without ALFA ROMEO CODE, but with anti-theft system

## COMPONENTS AND CONNECTORS (cont.d)

Engine sensors connector		<b>G308</b>
<p>(*) 2.5RED-BLK • I10</p> <p>2.5RED-BLK • B1</p> <p>GRN • C10</p> <p>2.5RED-BLK • A11</p> <p>GRN • G332</p>		
Alternator connector for recharging signal		<b>G332</b>
<p>GRN • A3</p> <p>GRN • G308</p>		
Starting consent relay(*)	<b>I10</b>	Anti-theft control unit(*)
<p>2.5RED-GRN • G241</p> <p>2.5RED-BLK • G308</p> <p>2.5BLK • G53b</p> <p>1.5YEL-RED • G241</p> <p>2.5WHT-RED • B1</p> <p>4RED • G56</p> <p>2.5RED 30</p>		<p>1YEL-RED • G241</p>
Anti-theft control unit (*)		<b>N45</b> <b>A</b>
Anti-theft control unit (*)		<b>N45</b> <b>B</b>
<p>5 1RED-GRN • G241</p> <p>6 1RED-BLK • G241</p>		

(\*) Variant for cars without ALFA ROMEO CODE, but with anti-theft system

## LOCATION OF COMPONENTS (Boxer versions)

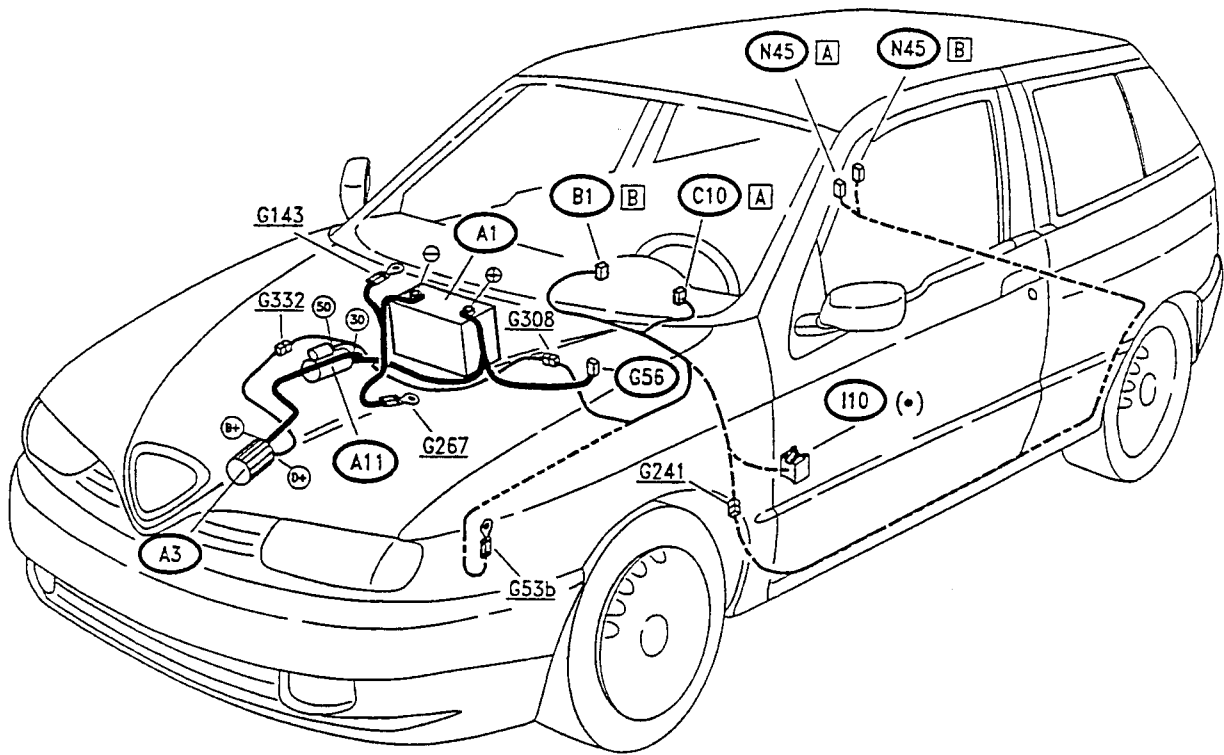

----- Variant for cars without ALFA ROMEO CODE, but with anti-theft system

(•) yellow base

## WIRING DIAGRAM (TD version - up to chassis no.....)

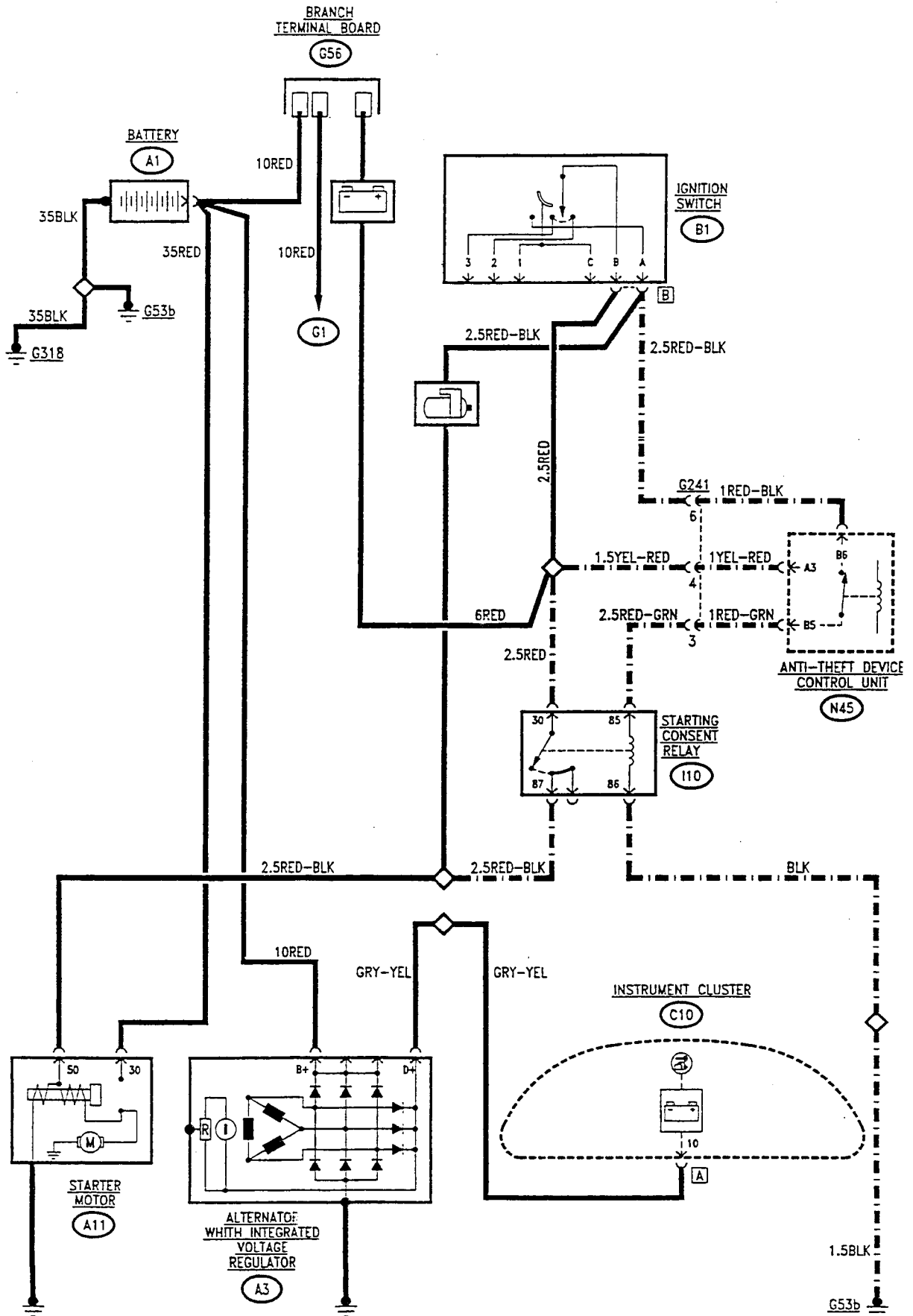

--- variant for cars without ALFA ROMEO CODE, but with theft alarm



### WIRING DIAGRAM (TD version - from chassis no.....)

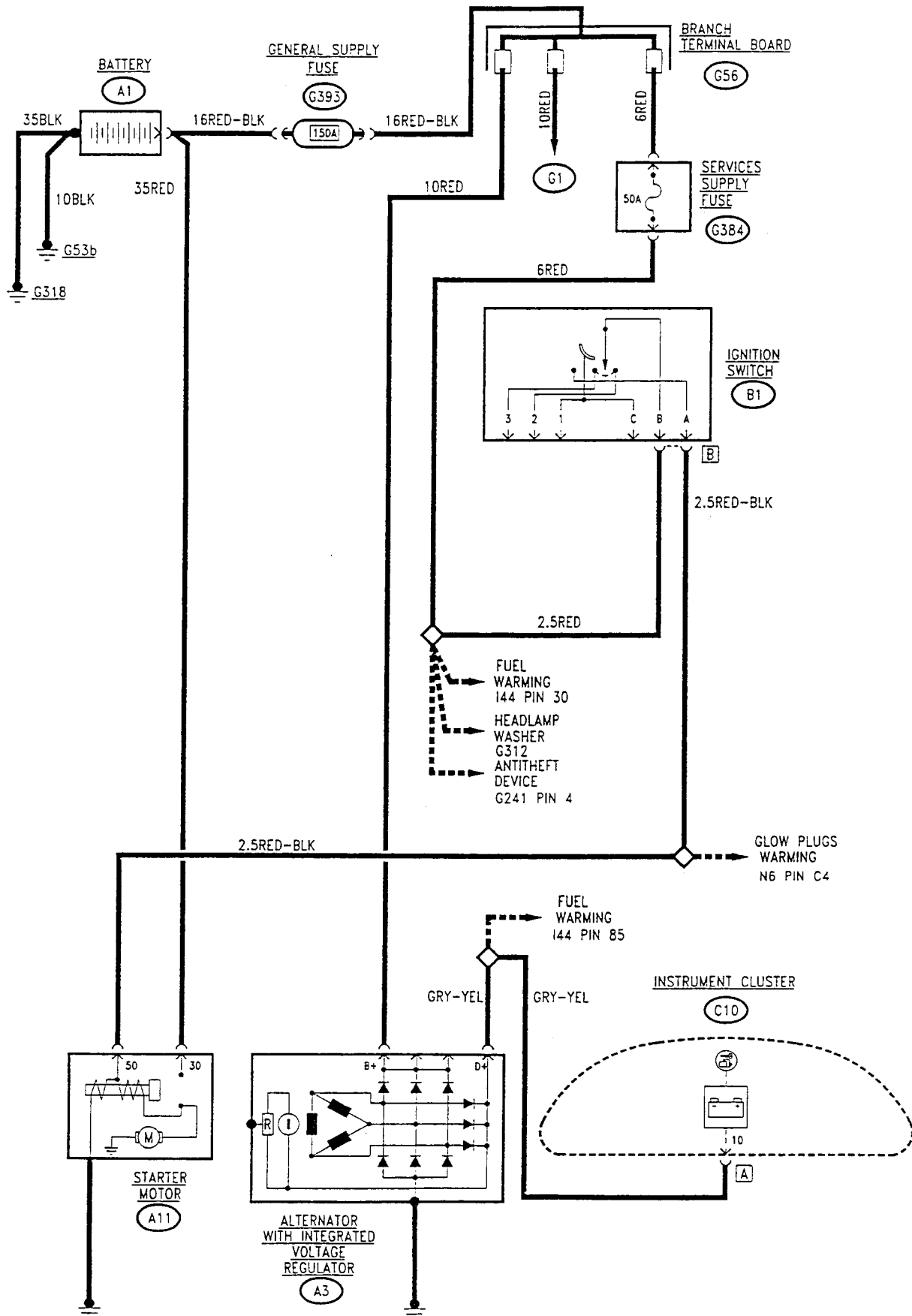

## WIRING DIAGRAM (TD-CAT version)

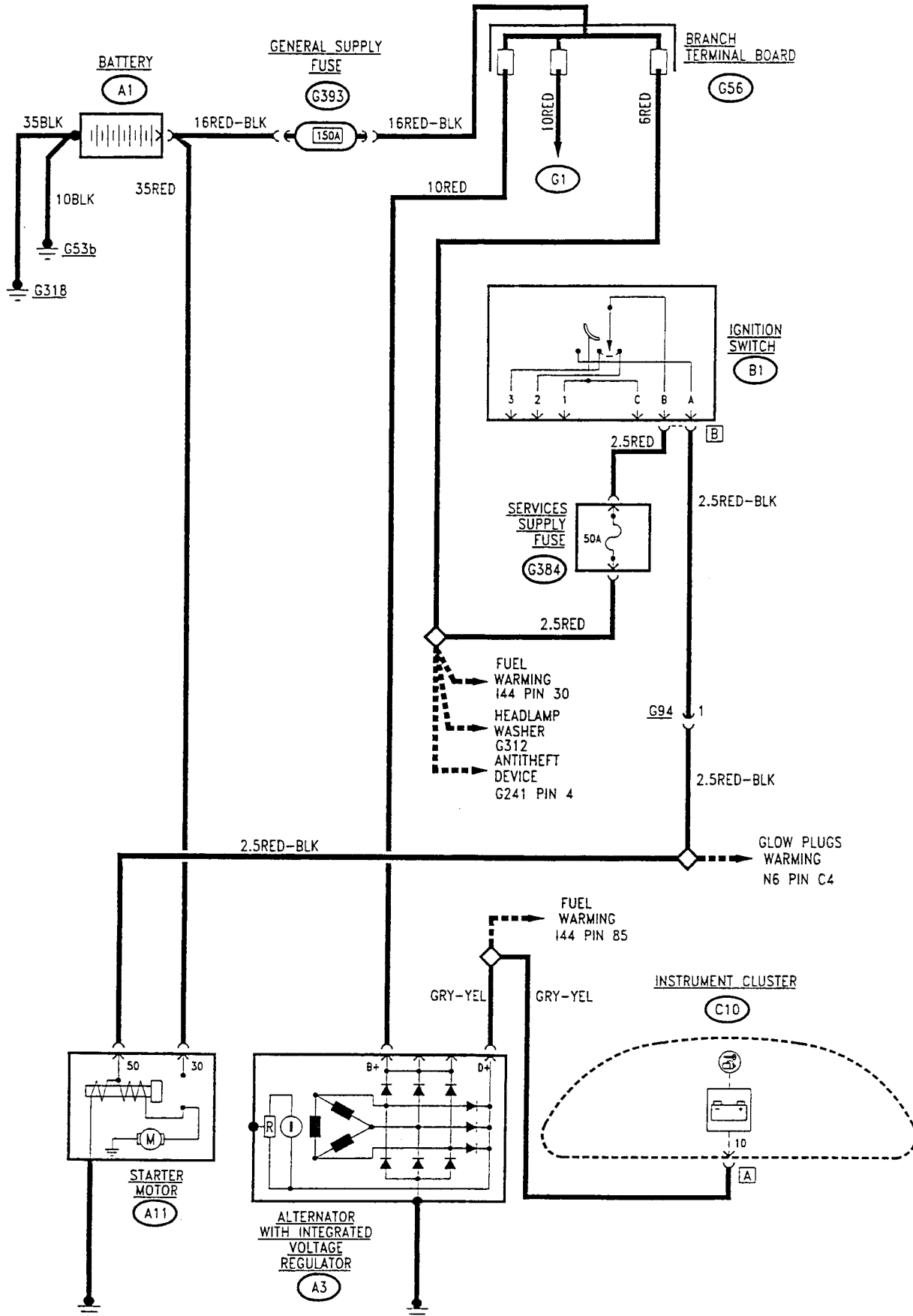

**FUNCTIONAL DESCRIPTION****(TD version)**

When the key in the ignitions switch **B1** is turned to the "START" position, it energises the winding of the electromagnet (pin 50) of the starter motor **A11** and supplies (pin 30) the starter motor itself with current leading directly from the battery **A1** thereby cranking the engine (in cars without ALFA ROMEO CODE, but fitted with car alarm, the starter motor supply "crosses" the theft alarm control unit **N45** (pin B5 - B6) which cuts off the supply in the event of an alarm and the starting consent relay **I10**).

When the engine is running, the direct current generated by the alternator **A3** (pin B+) is sent to recharge the battery **A1**; from chassis no..... via the branch terminal box **G56** .

All the lines for supplying the various electric systems of the car branch from the terminal box **G56** connected to the + terminal of the battery **A1** (see "Supply").

When the alternator is not turning and therefore not charging the battery, an earth signal is sent from pin D+ to the instrument cluster **C10** to turn on the corresponding warning light; once the engine has been started this signal becomes 12 V and the warning light goes off.

**FUNCTIONAL DESCRIPTION****(TD-CAT version)**

When the key in the ignitions switch **B1** is turned to the "START" position, it energises the winding of the electromagnet (pin 50) of the starter motor **A11** and supplies (pin 30) the starter motor itself with current leading directly from the battery **A1** thereby cranking the engine.

When the engine is running, the direct current generated by the alternator **A3** (pin B+) is sent to recharge the battery **A1**; via the branch terminal box **G56** .

All the lines for supplying the various electric systems of the car branch from the terminal box **G56** connected to the + terminal of the battery **A1** (see "Supply").

When the alternator is not turning and therefore not charging the battery, an earth signal is sent from pin D+ to the instrument cluster **C10** to turn on the corresponding warning light; once the engine has been started this signal becomes 12 V and the warning light goes off.

## COMPONENTS AND CONNECTORS (TD version)

Battery		A1
Alternator, with built-in voltage regulator	A3	Starter motor
Starter motor	A11	Ignition switch
Ignition switch	B1 B	Instrument cluster

(\*) Versions without ALFA ROMEO CODE, but with anti-theft system  
PA493000000006

(\*) Variant from chassis no....

### COMPONENTS AND CONNECTORS (contd.)

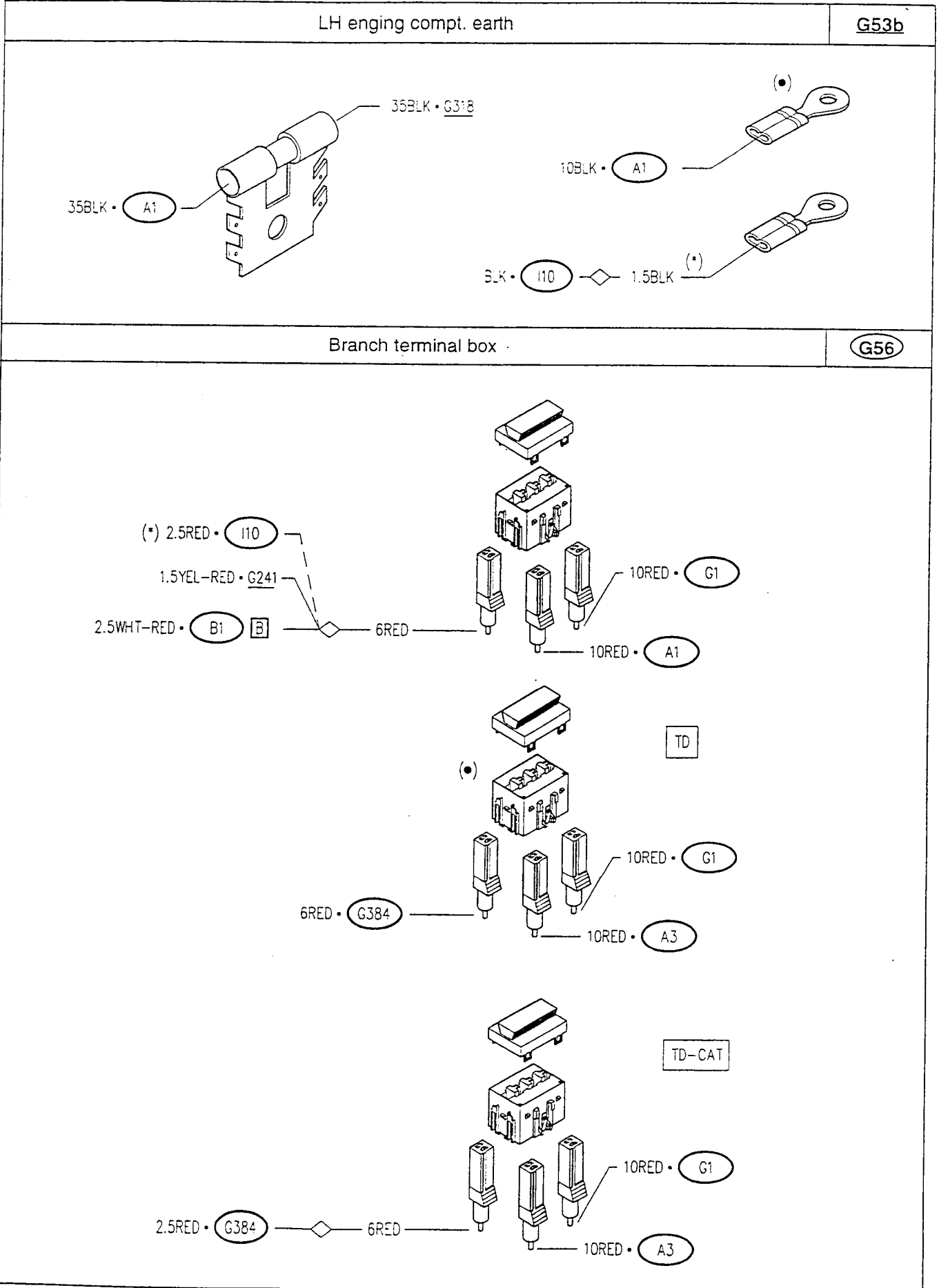

(\*) Versions without ALFA ROMEO CODE, but with anti-theft system  
PA49300000006

(•) Variant from chassis no....

### COMPONENTS AND CONNECTORS (contd.)

Engine compartment connection

**G94**

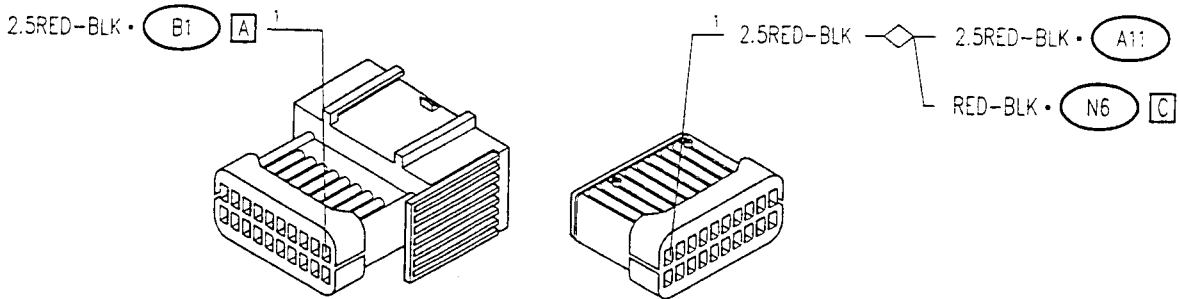

Alarm wiring connector (\*)

**G241**

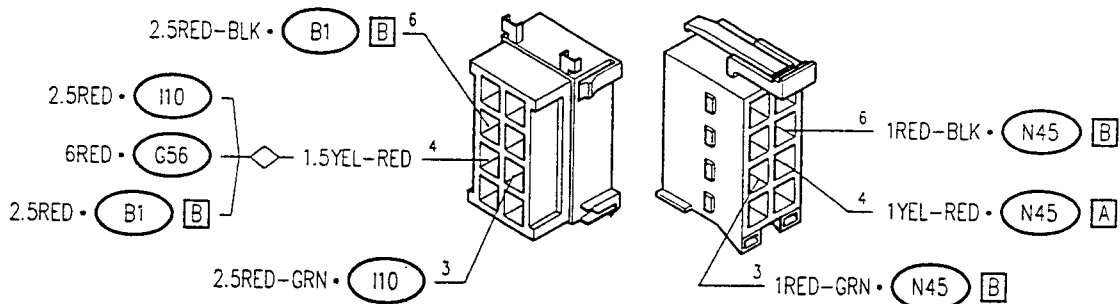

Earth on gearbox

**G318**

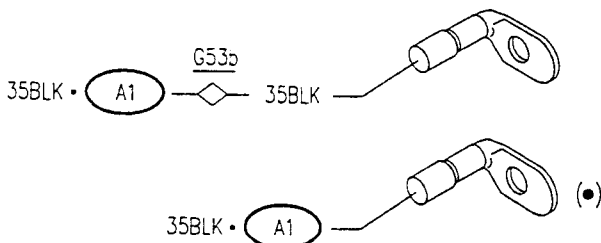

Services supply fuse

**G384**

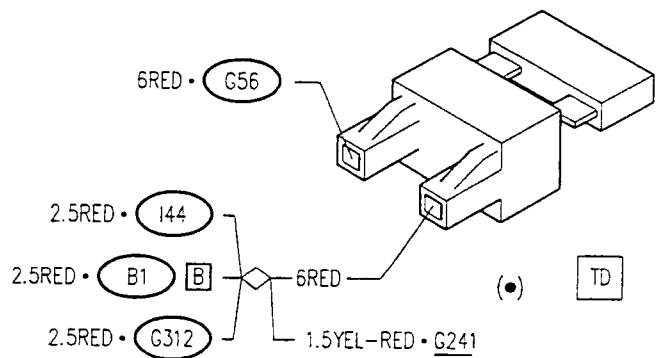

Services supply fuse

**G384**

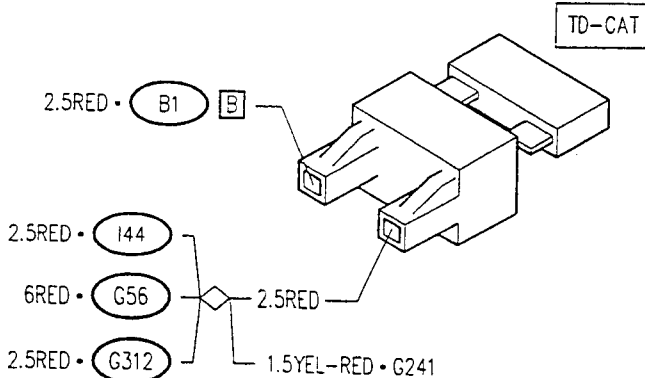

General supply fuse (\*)

**G393**

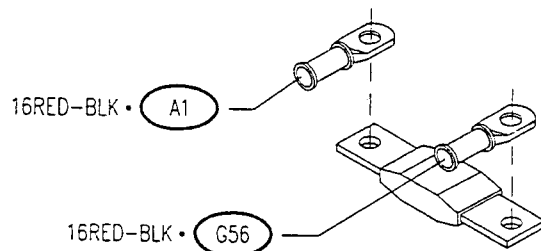

(\*) Versions without ALFA ROMEO CODE, but with anti-theft system  
PA49300000006

(\*) Variant from chassis no....

### COMPONENTS AND CONNECTORS (contd.)

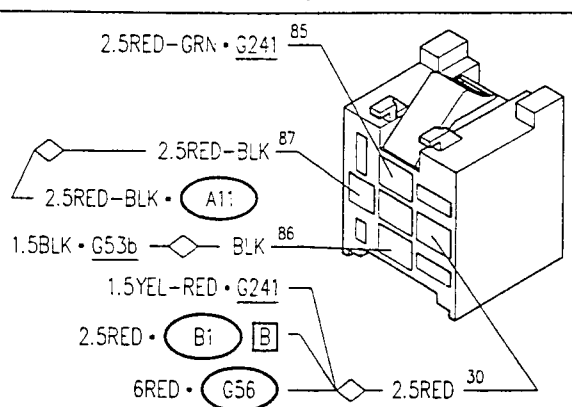
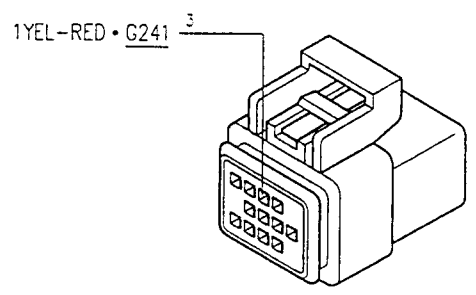
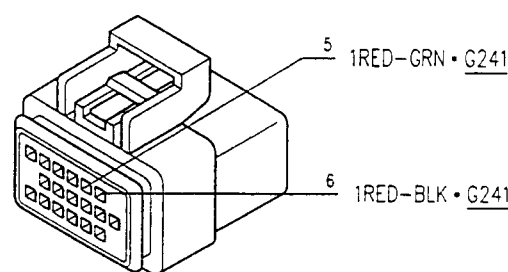
Starting consent relay (*)		I10
		
Alarm control unit (*)	N45 A	Alarm control unit (*)
		

(\*) Versions without ALFA ROMEO CODE, but with anti-theft system

### LOCATION OF COMPONENTS (TD version)

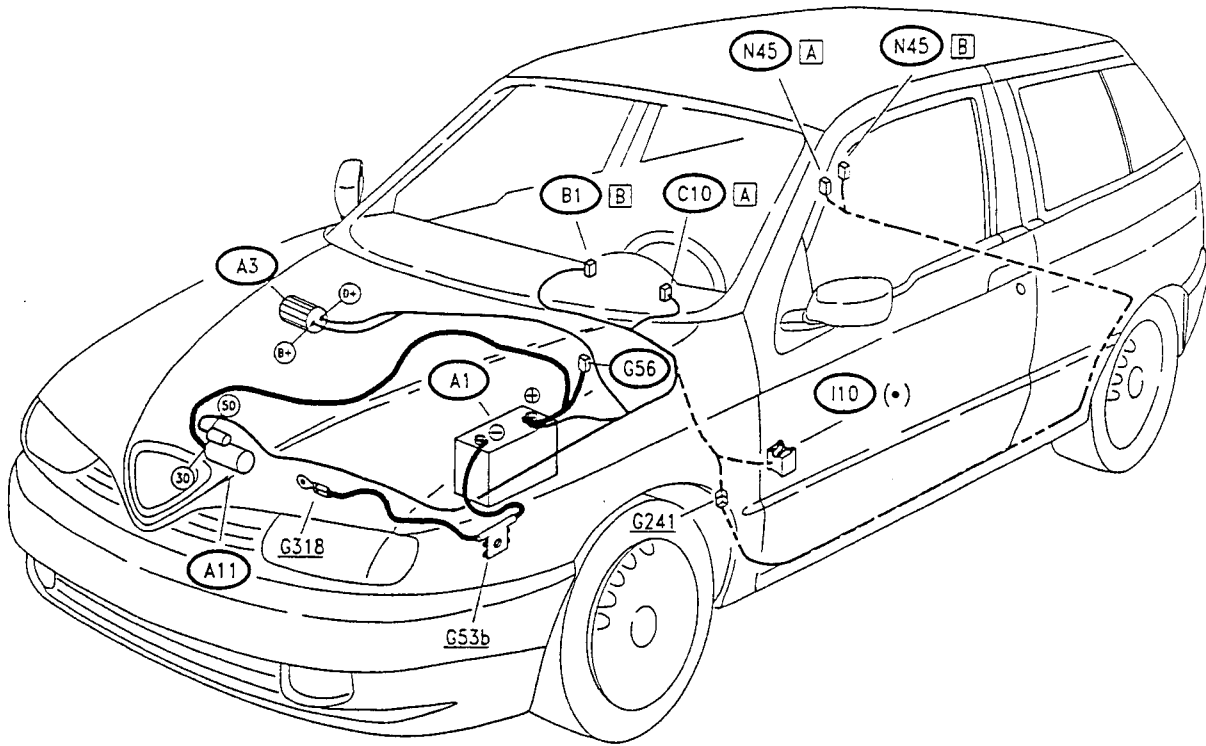

Variant from chassis no.....

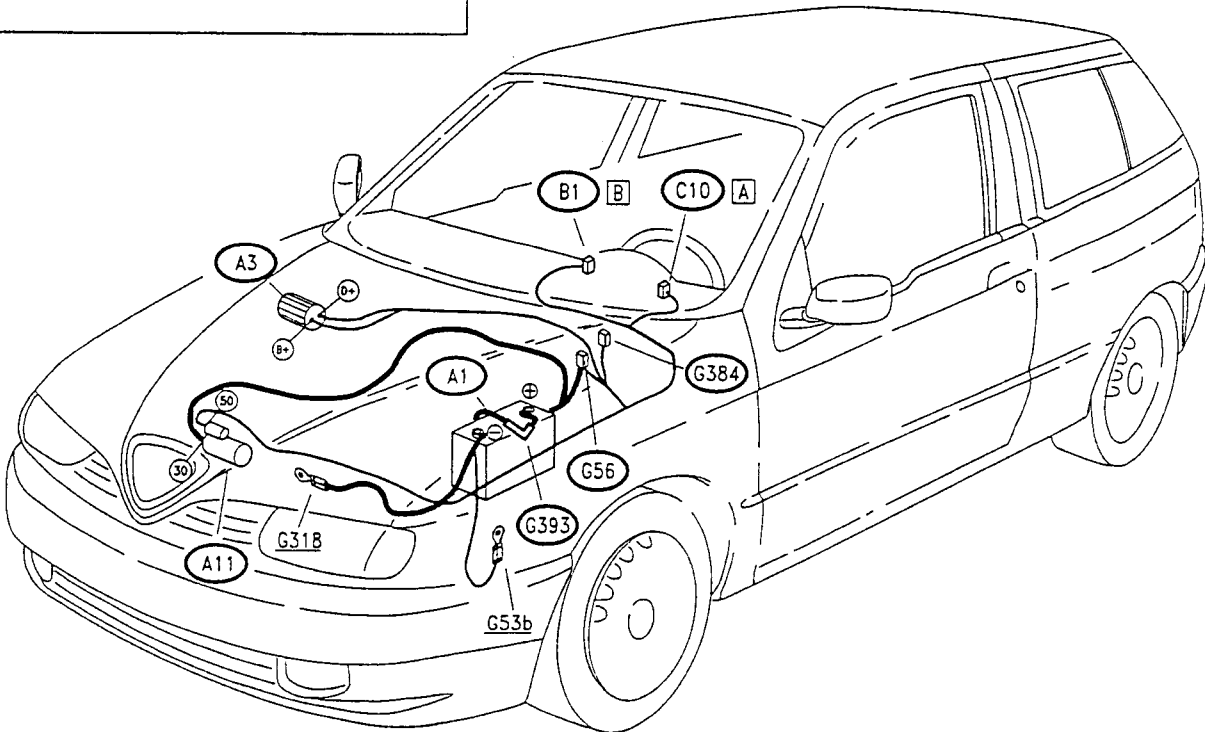

----- variant for cars without ALFA ROMEO CODE, but with theft alarm

(•) yellow base



## LOCATION OF COMPONENTS (TD-CAT version)

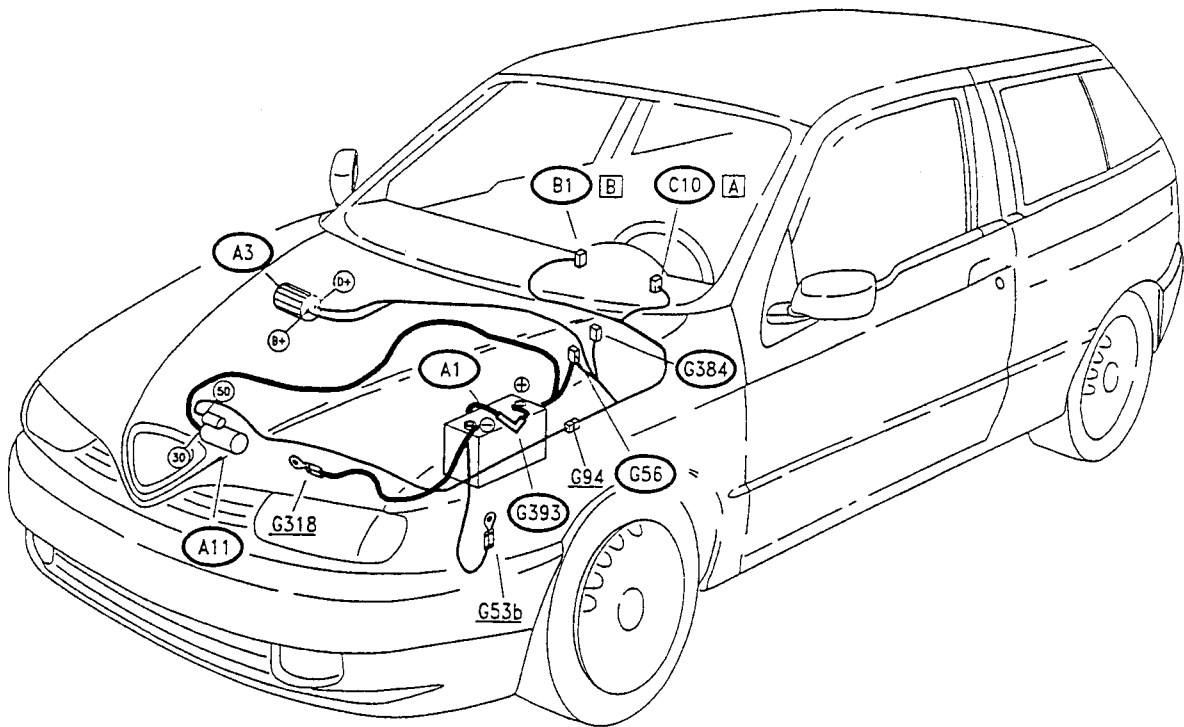

## WIRING DIAGRAM (T.SPARK version)

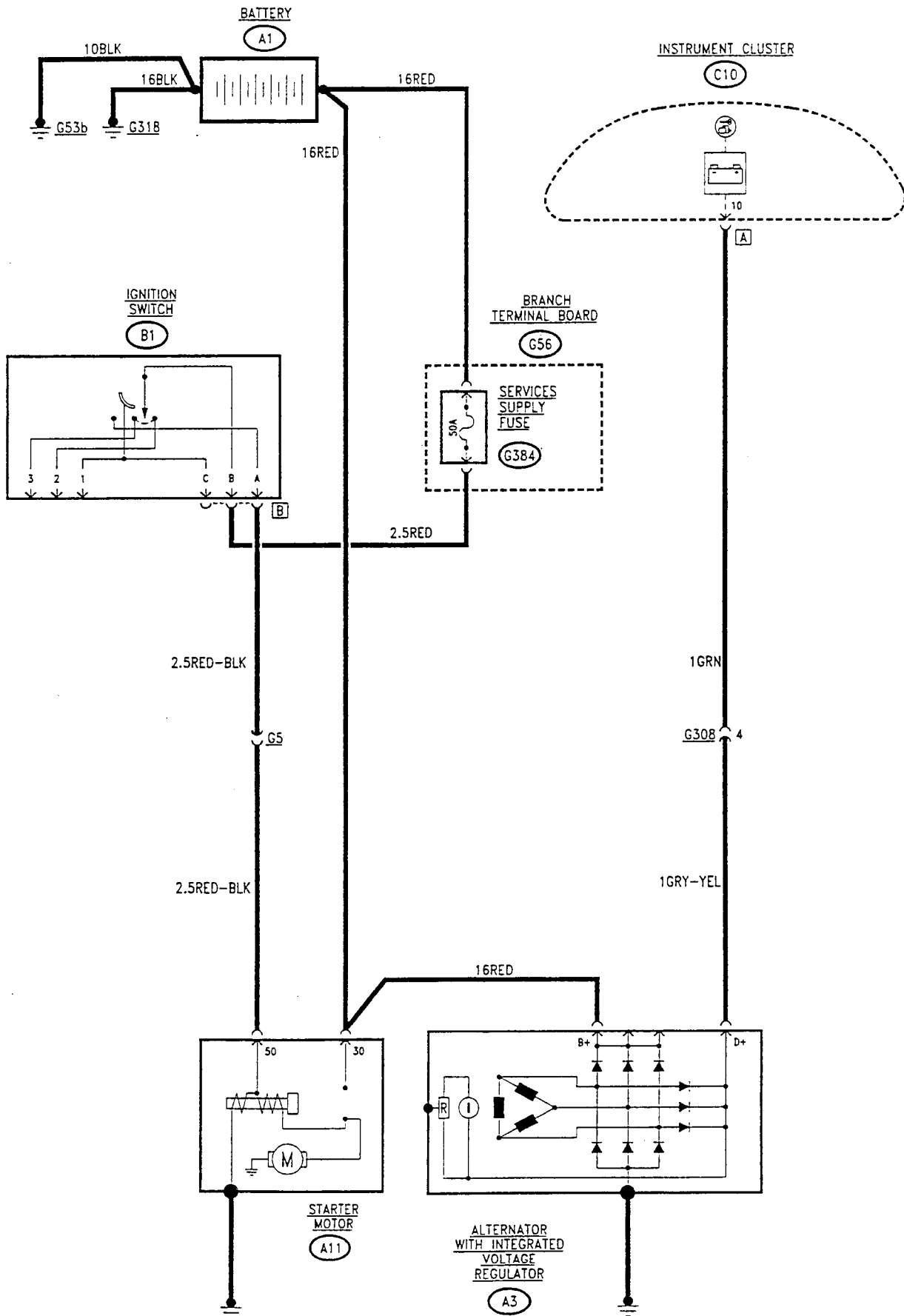

## FUNCTIONAL DESCRIPTION (T.SPARK version)

When the key in the ignitions switch **B1** is turned to the "START" position, it energises the winding of the electromagnet (pin 50) of the starter motor **A11** and supplies (pin 30) the starter motor itself with current leading directly from the battery **A1** thereby cranking the engine.

When the engine is running, the direct current generated by the alternator **A3** (pin B+) is sent to recharge the battery **A1** via the starter motor **A11**.

All the lines for supplying the various electric systems of the car branch from the terminal box **G56** connected to the + terminal of the battery **A1** (see "Supply"), in particular the supply for the ignition switch **B1** via fuse **G384** (50A)

When the alternator is not turning and therefore not charging the battery, an earth signal is sent from pin D+ to the instrument cluster **C10** to turn on the corresponding warning light; once the engine has been started this signal becomes 12 V and the warning light goes off.

## COMPONENTS AND CONNECTORS (T.SPARK version)

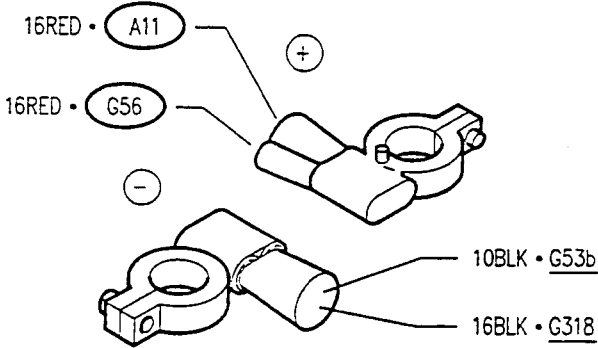
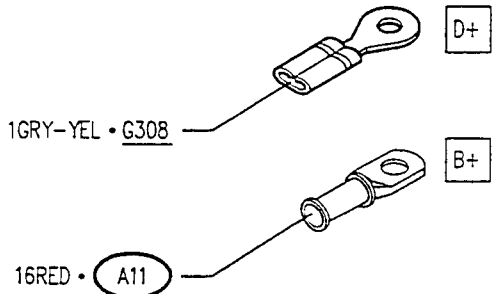
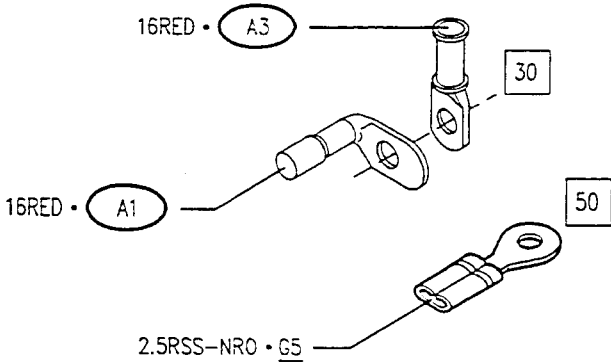
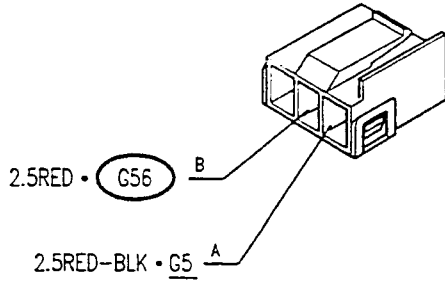
Battery	A1	Alternator, with built-in voltage regulator	A3
			
Starter motor	A11	Ignition switch	B1 B
			

## COMPONENTS AND CONNECTORS (contd.)

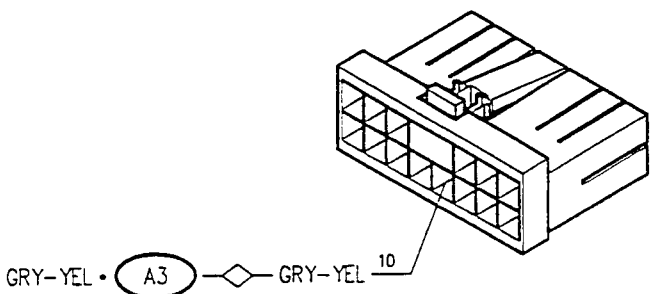
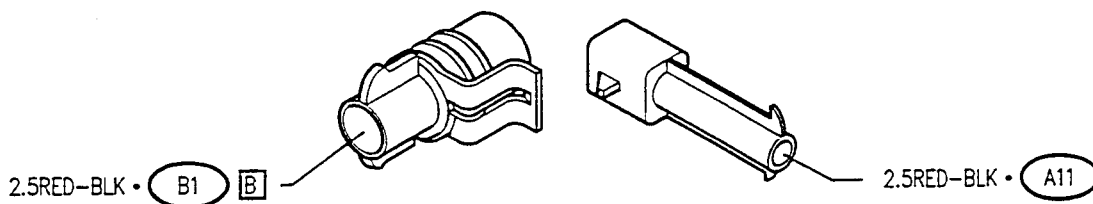
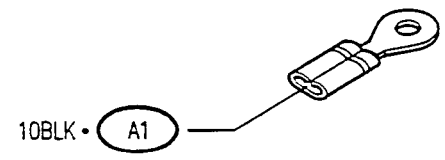
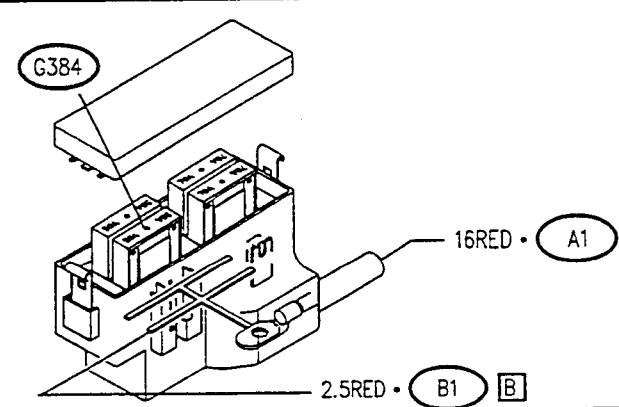
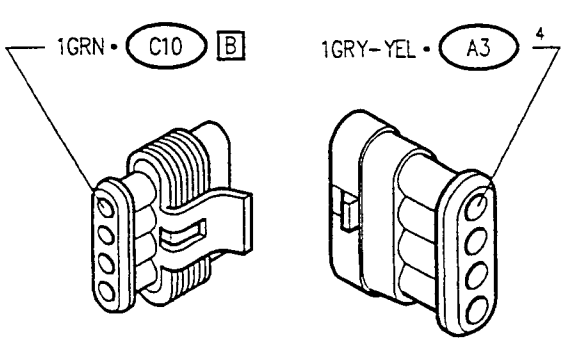
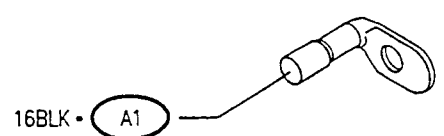
Instrument cluster		<b>C10</b> <b>A</b>
 <p>GRY-YEL • <b>A3</b> — GRY-YEL 10</p>		
Single connector		<b>G5</b>
 <p>2.5RED-BLK • <b>B1</b> <b>B</b>      2.5RED-BLK • <b>A11</b></p>		
LH engine compt. earth	<b>G53b</b>	Branch terminal box <b>G56</b>
 <p>10BLK • <b>A1</b></p>	 <p><b>G384</b>      16RED • <b>A1</b>      2.5RED • <b>B1</b> <b>B</b></p>	
Engine sensors connector	<b>G308</b>	Earth on gearbox <b>G318</b>
 <p>1GRN • <b>C10</b> <b>B</b>      1GRY-YEL • <b>A3</b> 4</p>		 <p>16BLK • <b>A1</b></p>

## LOCATION OF COMPONENTS (T.SPARK version)

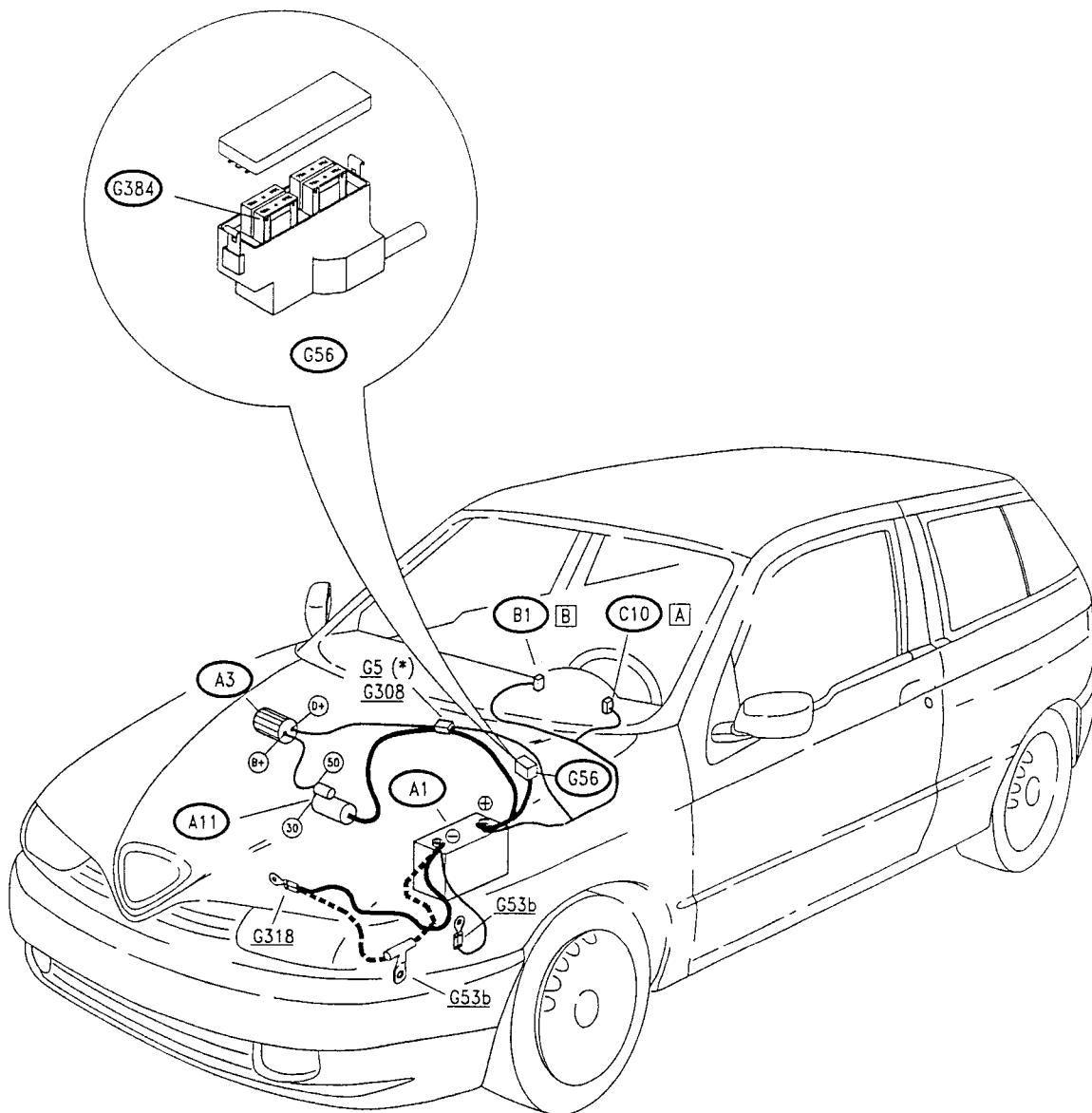

(\*) Up to Model Year '97  
 — — — From Model Year '98

## WIRING DIAGRAM (JTD version)

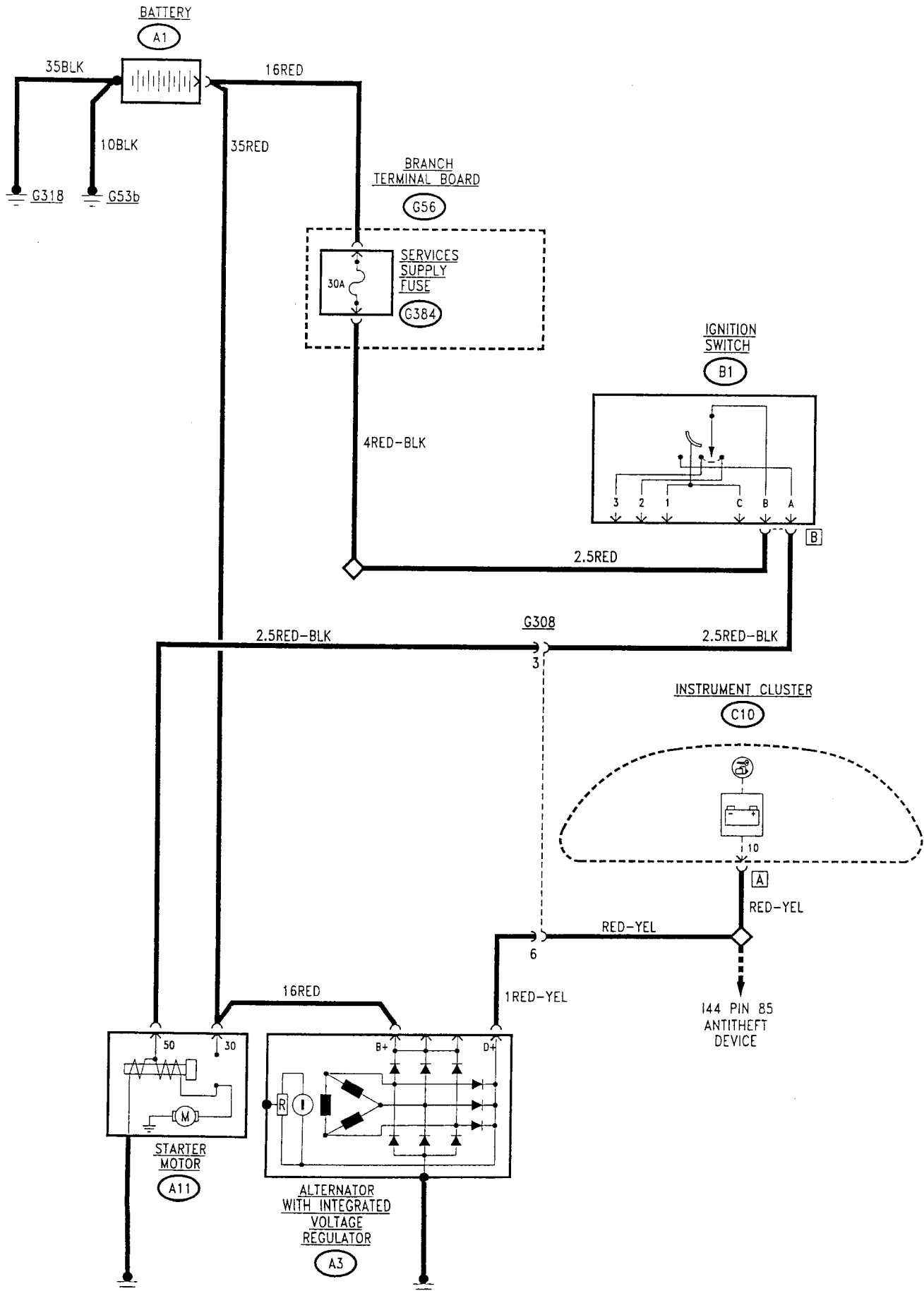

## FUNCTIONAL DESCRIPTION (JTD version)

When the key in the ignitions switch **B1** is turned to the "START" position, it energises the winding of the electromagnet (pin 50) of the starter motor **A11** and supplies (pin 30) the starter motor itself with current leading directly from the battery **A1** thereby cranking the engine.

When the engine is running, the direct current generated by the alternator **A3** (pin B+) is sent to recharge the battery **A1** via the starter motor **A11**.

All the lines for supplying the various electric systems of the car branch from the terminal box **G56** connected to the + terminal of the battery **A1** (see "Supply"), in particular the supply for the ignition switch **B1** via fuse **G384** (30A). When the alternator is not turning and therefore not charging the battery, an earth signal is sent from pin D+ to the instrument cluster **C10** to turn on the corresponding warning light; once the engine has been started this signal becomes 12 V and the warning light goes off.

## COMPONENTS AND CONNECTORS (JTD version)

<p>Battery</p>	<p><b>A1</b></p>	<p>Alternator, with built-in voltage regulator</p>	<p><b>A3</b></p>
<p>Starter motor</p>	<p><b>A11</b></p>	<p>Ignition switch</p>	<p><b>B1</b> <b>B</b></p>
<p>Instrument cluster</p>	<p><b>C10</b> <b>A</b></p>	<p>LH engine compartment earth</p>	<p><b>G53b</b></p>

## COMPONENTS AND CONNECTORS (contd.)

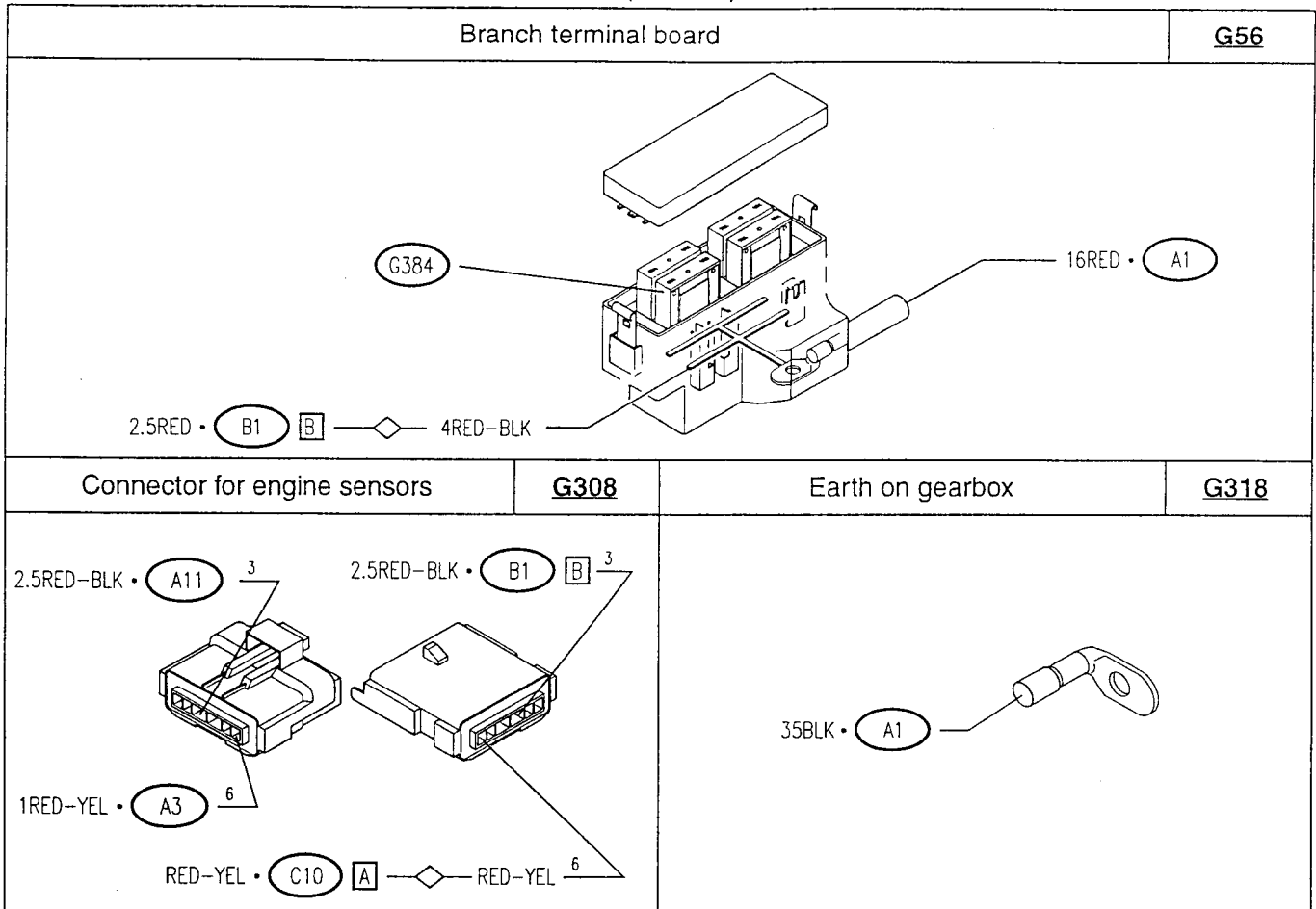



## LOCATION OF COMPONENTS (JTD version)

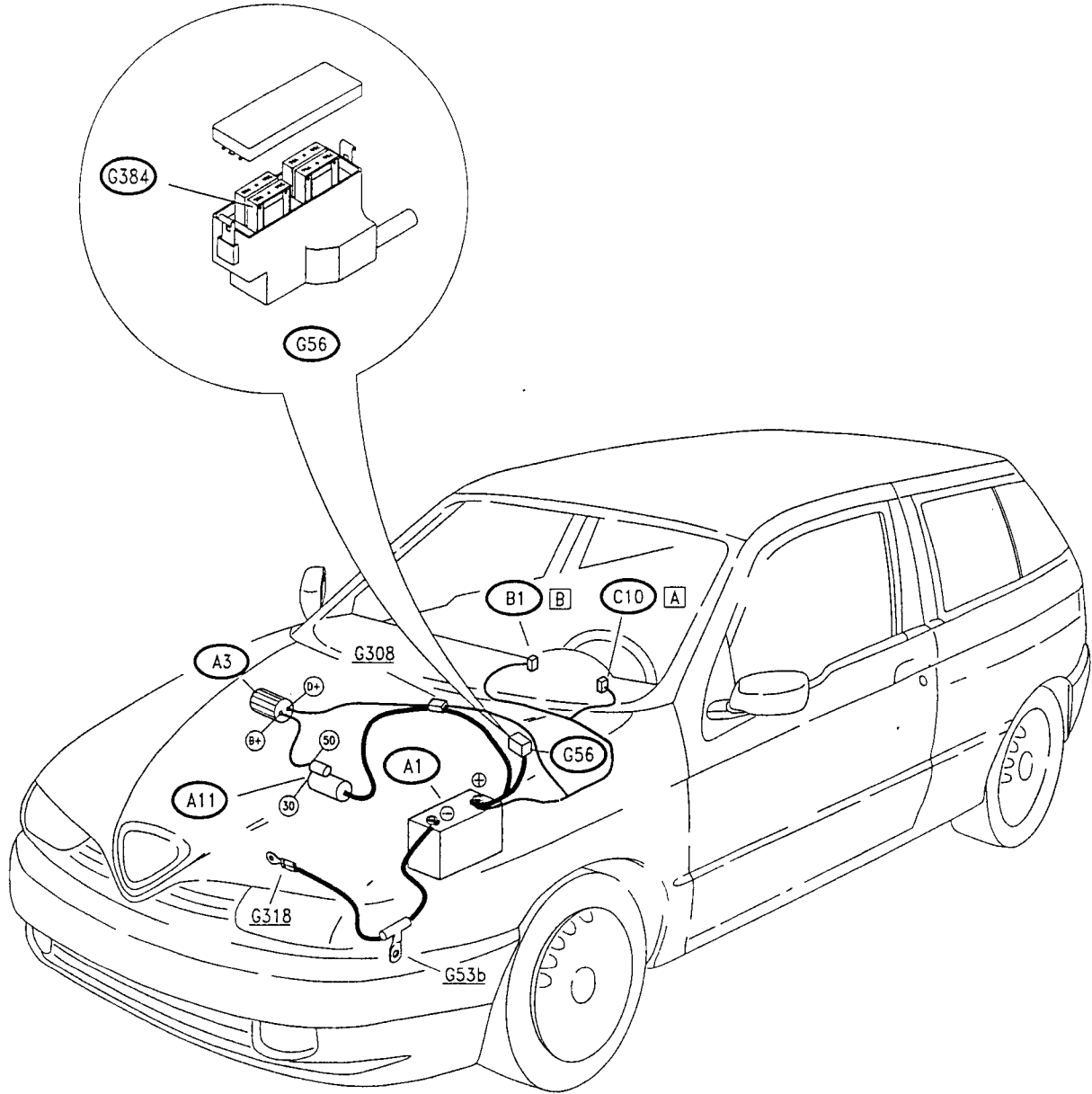

### FAULT-FINDING TABLE

Fault	Component to be checked						
	A1	B1	G384 (*)	A11	A3	C10 (2)	I10 (1)
Engine starting (1)	•	•	•	•			•
Charging	•				•		
Charge warning light					•	•	

(1) Only for cars **without** ALFA ROMEO CODE, but **with** theft alarm: beforehand check that the theft alarm is working properly (see "Theft Alarm" section) as it may have cut off the supply to the starter motor.

(2) The instrument cluster **C10** cannot be overhauled. Therefore, in the event of a fault it is not possible to replaced individual warning lights and a complete new instrument cluster must be installed.

(\*) TD version only, from chassis no.....; T.SPARK and JTD

### CHECKING COMPONENTS

#### Ignition switch **B1**

Check the internal connections following the table below:

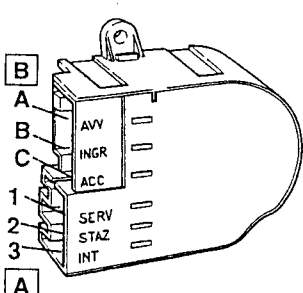
Reed identification codes	POSITION OF KEY			
	PARK	key can be removed	STOP key can be removed	DRIVE key not removable
 <p>AVV INGR ACC SERV STAZ INT</p>	□		□ □ □	□ □ □

#### Starter motor **A11**

If necessary, refer to the starter motor specifications and instructions given in the section "ELECTRIC SYSTEM-ENGINE STARTING"

#### Alternator **A3**

If necessary, refer to the starter motor specifications and instructions given in the section "ELECTRIC SYSTEM-CURRENT GENERATION"

#### Battery **A1**

If necessary, refer to the starter motor specifications and instructions given in the section "ELECTRIC SYSTEM-CURRENT GENERATION"